



"Pursuing Safety Through Technology"

US Patent # 6,384,742

THE LIGHTGUARD SYSTEMS[®] INSTALLATION AND USER MANUAL & FACTORY RECOMMENDED GUIDELINES

Copyright © 1999 LightGuard Systems, Inc.

November 2011

LightGuard Systems, Inc.

2292 Airport Blvd.
Santa Rosa, CA 95403-1003
707-542-4547 Ph.
707-525-6333 Fax

www.crosswalks.com

Copyright © 1999 by LightGuard Systems, Inc. (LGS). All rights reserved. Printed in the United States of America. Except as permitted under the Copyright Act of 1976, no part of this publication may be reproduced or distributed in any form or by any means, or stored in a database or retrieval system, without the prior written permission of the publisher. This information is provided for information purposes only. LGS disclaims all warranties whether express or implied and specifically disclaims all implied warranties of merchantability and fitness for a particular purpose. Failure to comply with recommendations or guidelines will result in a void of product warranty.

TABLE OF CONTENTS

1	THE LIGHTGUARD SYSTEM® AND COMPONENTS.....	2
1.1	THE LIGHTGUARD SYSTEM®	2
1.2	POWER SYSTEM	2
1.3	IN-ROADWAY WARNING LIGHT (IRWL) SIGNAL HEAD	2
1.4	SYSTEM ACTIVATION; AUTOMATIC/MANUAL/CONTINUOUS/PROGRAM	2
1.5	LED “ENHANCED” PEDESTRIAN CROSSING SYMBOL SIGN	3
1.6	LGS COMPONENTS NEEDED FOR A TYPICAL SMART CROSSWALK™	3
1.7	SUGGESTED INSTALLATION EQUIPMENT, MATERIALS AND TOOLS	5
2	POWER SYSTEM AND COMPONENTS	6
2.1	POWER SYSTEM DESCRIPTION	6
2.2	TYPICAL LIGHTGUARD SYSTEM® WIRING DIAGRAM	6
2.3	AC SYSTEM	7
2.4	SOLAR SYSTEM	9
2.5	ECP SYSTEM (ECP-1 & ECP-2).....	11
2.6	ENCLOSURE POLE MOUNT DETAIL.....	13
2.7	BACK PANEL ELECTRICAL CONNECTIONS	13
2.8	POWER CONTROL UNIT (PCU) DESCRIPTION.....	15
3	IN-ROADWAY WARNING SIGNAL (IRWL)	21
3.1	GENERAL DESCRIPTION	21
3.2	MAJOR CONSIDERATIONS FOR LIGHTGUARD SYSTEM IRWL INSTALLATION	21
3.3	CONCRETE INSTALLATION PROCEDURE	24
3.4	IRWL SIGNAL AND BASE PLATE INSTALLATION GUIDELINES	25
3.5	IRWL SAW CUT CROSS-SECTION DIAGRAMS	26
3.6	TYPICAL IRWL SIGNAL BASE PLATE WIRING DRAWING	27
3.7	CONVERGENCE ZONES.....	29
4	AUTOMATIC ACTIVATION SYSTEM - SMART CROSSWALK™	31
4.1	AUTOMATIC BOLLARD DETECTION SYSTEM DESCRIPTION	31
4.2	BOLLARD DRAWING	31
4.3.	BOLLARD INSTALLATION GUIDELINES	32
4.4	BOLLARD SENSOR ADJUSTMENT	34
4.5.	BOLLARD ALIGNMENT	34
4.6.	BOLLARD DETECTION ZONE OPERATION	36
4.7	UNI-BOLLARD / ISAD INSTALLATION OPTION	37
5	PUSH BUTTON ACTIVATION.....	40
5.1	MANUAL PUSH BUTTON ACTIVATION DESCRIPTION	40
5.2	ILLUMINATED PUSH BUTTON ASSEMBLY.....	40
5.3	SAMPLE PUSH BUTTON LAYOUT AND WIRING DIAGRAM	40
5.4	PUSH BUTTON INSTALLATION DETAIL DRAWING	41
6	LED “ENHANCED” ILLUMINATED WARNING SIGNS.....	42
6.1	LED “ENHANCED” SIGN GENERAL DESCRIPTION.....	42
6.2	LED “ENHANCED” PEDESTRIAN CROSSING SIGN DRAWING	42
7	LIGHTGUARD SYSTEMS SOLAR POWER OPTION	43
7.1	INSTALLATION STEPS	43
7.2	SOLAR MODULE	43
7.3	SOLAR SYSTEM BATTERIES	45
7.4	CHARGE CONTROLER.....	46
8	TROUBLE SHOOTING / MAINTENANCE / AFTER INSTALLATION.....	47
8.1	TROUBLE SHOOTING GUIDE	47
8.2	INITIAL INSTALLATION	48
8.3	FIELD RELATED TOTAL PREVENTATIVE MAINTENANCE	48
8.4	EQUIPMENT LIST	49
9	ADDENDUMS	50

1 THE LIGHTGUARD SYSTEM[®] AND COMPONENTS

1.1 THE LIGHTGUARD SYSTEM[®]

The LightGuard System[™] (the System) is designed for applications at mid-block or uncontrolled intersection crosswalks and other roadway crossings. It is entirely compliant with the MUTCD and in many cases, the MUTCD text was composed with the LightGuard Systems product development and testing in mind.

The System utilizes a series of light emitting diodes (LED's) in a durable housing embedded in the roadway which flashes, in a unidirectional manner, a warning to approaching motorists that a pedestrian is in or entering the crosswalk. The in-roadway LED warning signals are aimed down the motorist-viewing path of the approaching driver to allow the flashing lights to be easily seen by motorists along the full length of the un-obscured viewing approach path. The lights flash for a set period of time before automatically turning off. The System can be activated by a pedestrian pushing a button, or automatically when a pedestrian passes through an activation zone breaking an optical beam. It can be a stand-alone solar-powered System, or a conventional AC powered System with battery back up.

The LightGuard System[™] comprises the following components and all components must work in unison.

1.2 POWER SYSTEM

A roadside, or pole mounted, cabinet contains all of the LED drive electronics and field wiring electrical interfaces. Both the AC & the ECP systems operate off a 12 VDC power supply from an AC line. The AC system can be energized from either 110V single phase or 220V two-phase power. The ECP can only be energized from 110V single phase. The Solar System operates off of 12 VDC battery power and is recharged during daylight hours from a Solar PV panel.

Based on a typical installation, power usage is approximately 18 - 20 watts depending on the type of activation mechanism. Total energy consumed (in KWH) is dependent upon the number of light fixtures, the cross time duration, and the number of activations. Circuit breakers protect internal circuitry and field wiring. The Power Control Unit (PCU) available in the AC & Solar Systems is based on a high speed 8 bit embedded microcontroller utilizing a compiled machine control language. LGS proprietary software program provides effective, reliable operation allowing the user simple operation adjustments with a keypad and display (LCD).

1.3 IN-ROADWAY WARNING LIGHT (IRWL) SIGNAL HEAD

The LightGuard System[™] In-Roadway Warning Light signal heads are manufactured of high strength impact resistant materials. They are designed to be mounted onto a metal or composite base plate assembly that is permanently attached to the roadway. This allows for easy replacement of any IRWL that may become damaged, or inoperable, for any reason.

1.4 SYSTEM ACTIVATION; AUTOMATIC/MANUAL/CONTINUOUS/PROGRAM

1.4.1 AUTOMATIC - Bollards

For AUTOMATIC activation, the System uses state-of-the-art electronic and software driven technology. The Smart Crosswalk[™] automatic system is a dual break-beam system utilizing modulated infrared sensors housed in decorative posts, or bollards, at each side of the

crosswalk. Direction of pedestrian travel is detected and allows activation of the System only upon entry, not when exiting. Custom designed bollards currently house the drive electronics for automatic activation. They can be positioned up to 50 feet apart.

1.4.2 MANUAL - Push Button or optional Key Switch operation

A standard push button assembly (if installed) may be depressed if the pedestrian chooses to MANUALLY activate the System. Unlike existing signage, when the pedestrian pushes the button an “ON” response from the System is immediately visible via flashing LED lights above the words “CROSS WITH CAUTION”. As an added benefit, the PCU automatically monitors frequency and direction of use. Other activation options include pre-set on-off times or Key Switch activation with a set “on” time operation. Keypad functions allow for up to three (3) automatic on-off times for each day of the week.

1.4.3 CONTINUOUS – CONSTANT ON

The Illuminated crosswalk system can be set for continuous flashing 24/7. This is NOT recommended for solar powered systems due to the continuous power drain affecting battery recharge.

1.4.4 PROGRAMMABLE – Pre-set on/off timer

The Illuminated crosswalk system can be programmed to activate for a predetermined duration with 3 different start stop times up to 7 days per week. Refer to section [2.8.4.11](#) for instructions.

1.5 LED “ENHANCED” PEDESTRIAN CROSSING SYMBOL SIGN

It is recommended that a new fluorescent-yellow-green color (FYG), diamond-shaped pedestrian crossing sign (W11A-2) with LED warning light modules at the “enhanced” flash rate, is installed with each System (FYG S2-1 or W66 type school symbol sign also available). The LED warning light modules are designed to flash in conjunction with activation of the System. This active LED pedestrian crossing sign enhances driver recognition of the System’s presence, especially in adverse weather conditions, and contributes to educating the motorist as to the meaning of the flashing array of in-roadway warning signals. The new W11A-2 sign, with the LightGuard embedded LED warning light modules, replaces the standard W-54 sign typically placed at the crosswalk site.

1.6 LGS COMPONENTS NEEDED FOR A TYPICAL SMART CROSSWALK™

(Typical Four Lane Roadway Crossing)

ITEM	QTY	SYSTEM DESCRIPTION
------	-----	--------------------

- | | | |
|----|----|--|
| 1) | 1 | <u>LightGuard Power Control Unit (PCU)</u>
This PCU is based on a high speed 8 bit embedded microcontroller utilizing a compiled machine control language. A keypad and LCD display is provided to allow simple user adjustments to the System parameters. The PCU includes LGS’s proprietary software program. |
| 2) | 1 | <u>Electronics Enclosure</u>
The enclosure is sized to allow mounting of all components necessary to control the System. The enclosure’s water-resistant design is based upon the United States National Electronic Manufacturer’s Association (NEMA) specifications. |
| 3) | 18 | <u>LGS In-roadway Warning Signal Assemblies</u>
The In-roadway Warning Signal assemblies are street-mounted to withstand normal vehicle traffic. The patent protected assemblies, including base plates, are a LGS proprietary design. |

- 4) 4 Automatic Activation System Bollards
Pedestrian detection bollards or posts for automatic activation of the Smart Crosswalk™ System are located at each crosswalk entrance zone. Optical beam interruption sensors are designed to activate the System automatically as the primary activation mechanism of the System.
- 5) 2 LED Enhanced Pedestrian Symbol Warning Sign
The fluorescent-yellow-green (FYG) color, diamond shaped pedestrian warning sign (W11A-2) is retrofitted with LED warning light modules. LED light modules are designed to flash at the same flash rate & in conjunction with activation of the LightGuard System™.
- 6) Lot Mount Assemblies
LGS approved standard mount assemblies are sized and configured appropriately to allow mounting of the enclosure, automatic activation sensors, active signs, and other any other equipment required to operate the System. Fasten hardware not included - tamper resistant hardware is recommended for sign attachment to mount assembly.
- 7) Lot Signal Head Spare Parts
Gel-plugs and O-ring.
- 8) Lot Cable/wiring
LGS approved multi-strand 8 conductor wiring (BELDEN 27601A), 18 AWG, can be provided to connect the activation assemblies to the System PCU. Stranded wire, 14 AWG, type RHW-2/USE-2/XLP (colors - BLK YEL & RED), **maximum OD 0.17"** can be provided to connect the In- Roadway Warning Signal assemblies to the System PCU.

OPTIONAL EQUIPMENT

- 9) Solar Power Assembly and Enclosure
Solar Power Assembly with modules includes; battery charge amp/load controller, sealed solar cell batteries, battery cable, wire, fusing, and T-blocks sized to adequately operate System.
- 10) ECP Assembly and Enclosure
ECP Assembly includes flashing unit controller and power supply
- 11) AC Beacon Interface
Modified PCU & DIN Rail connections for 2 separate 115VAC relays operating in either wig-wag or continuous mode
- 12) DC Beacon Interface
Modified PCU & DIN rail connections for 2 separate 12VDC relays operating in either wig-wag or continuous mode
- 13) Audible crosswalk Interface
Modified PCU and DIN rail connections for various audible systems (voice, chirp, tweet, etc.)
- 14) Dual Zone Upgrade Kit
Modified PCU & DIN rail connections for 2 independent cross walk zones (activates flashing at 2 separate crosswalks)

1.7 SUGGESTED INSTALLATION EQUIPMENT, MATERIALS AND TOOLS

The general list below may include all equipment, materials, or tools required for installation.

Typical electrical tools used in street lighting and signal work

- Inch pound torque wrench
- End wrenches & sockets
- Crescent wrenches
- Allen wrenches
- Hammers - 3 lb. & claw
- Hack saw, File, & Knife
- Wire strippers
- Slip Joint Channel Lock Pliers
- Chisel
- 1/8" hex socket
- Taps & Dies
- 2 Putty knives x 4 inches wide
- Cordless drill with assorted drill bits 0.250 inches to 1 inch & hole saws 1 inch & 1.5 inches
- Rotor hammer - 1 inch bit & 1.5 inches bit
- Skill saw & blades
- Small hand held grinder
- Latex gloves – disposable
- AC DC meter
- Container and mixing tool for 2-part adhesive

-
- 100 foot measuring tape
 - Black & red electrical tape
 - **Grinding Core Drill:** Best Practice Custom “Flat Bottom” Core Drill: Best Practice Custom “Flat Bottom” Core Drill to eliminate the need for removing excess material from cored depression cut. Contact LightGuard Systems for more information about availability.
 - Duct Seal
 - Fish tape

-
- Air-blower (compressor)
 - Broom & dust pan
 - 1 Hose -garden type & fire hydrant adaptor
 - Wheelbarrow
 - Shovel – square point & round point
 - Rope

-
- Loop (saw cut) sealant
 - Conduit sealer
 - BONDO 7084 Adhesive (industrial 2-part epoxy) refer to section [3.2.7](#)
 - 5-gallon pail of .75 inch rock for under traffic valve boxes
 - Generator, with extension cord, for auxiliary power
 - Cut-off, mixed fuel, & spare blades
 - Power driven asphalt cutter (Saw cutter) capable of cutting ½ inches wide x 2 inches deep

-
- 1¼ inches *minimum* conduit as required by local agency (sizes can be determined by site engineer)
 - Reel wire holder ½ -inch diameter x 36 inches long, on stand (optional)

-
- **ALL NECESSARY EQUIPMENT FOR IMPLEMENTING AN APPROVED TRAFFIC CONTROL PLAN**
-

2 POWER SYSTEM AND COMPONENTS

2.1 POWER SYSTEM DESCRIPTION

An AC powered system uses either 115VAC single phase or 230VAC two phase as an energy source. A DPST 5A circuit breaker protects the both the *Line and Neutral* for single phase OR *both Lines* for two phase input. The AC power is transformed to 13.5 VDC via a 150W power supply. The 5A DPST circuit breaker is marked by the factory for both *Line & Neutral*, with one pole of the 5A DPST circuit breaker labeled “hot black” and the other labeled “neutral white”. For 2 phase operation, the label marked “neutral white” must be removed or otherwise placard over & the power supply switch must be reset to 230V prior to energizing the main 5A DPST circuit breaker on the back panel. The switch setting is normally factory configured for 115V & **MUST BE RESET** at time of installation for 2 phase 230V source. Refer to section [2.3.3](#) for switch location.

A Solar powered system uses a minimum 75W Photovoltaic array providing DC power to the internal batteries. All branch circuits have their own independent circuit protection in the Electronics Enclosure.

An ECP system uses 115VAC single phase as an energy source. A DPST 5A circuit breaker protects the both the Line and Neutral. The AC power is transformed to 13.5 VDC via a 150W power supply.

2.2 TYPICAL LIGHTGUARD SYSTEM® WIRING DIAGRAM

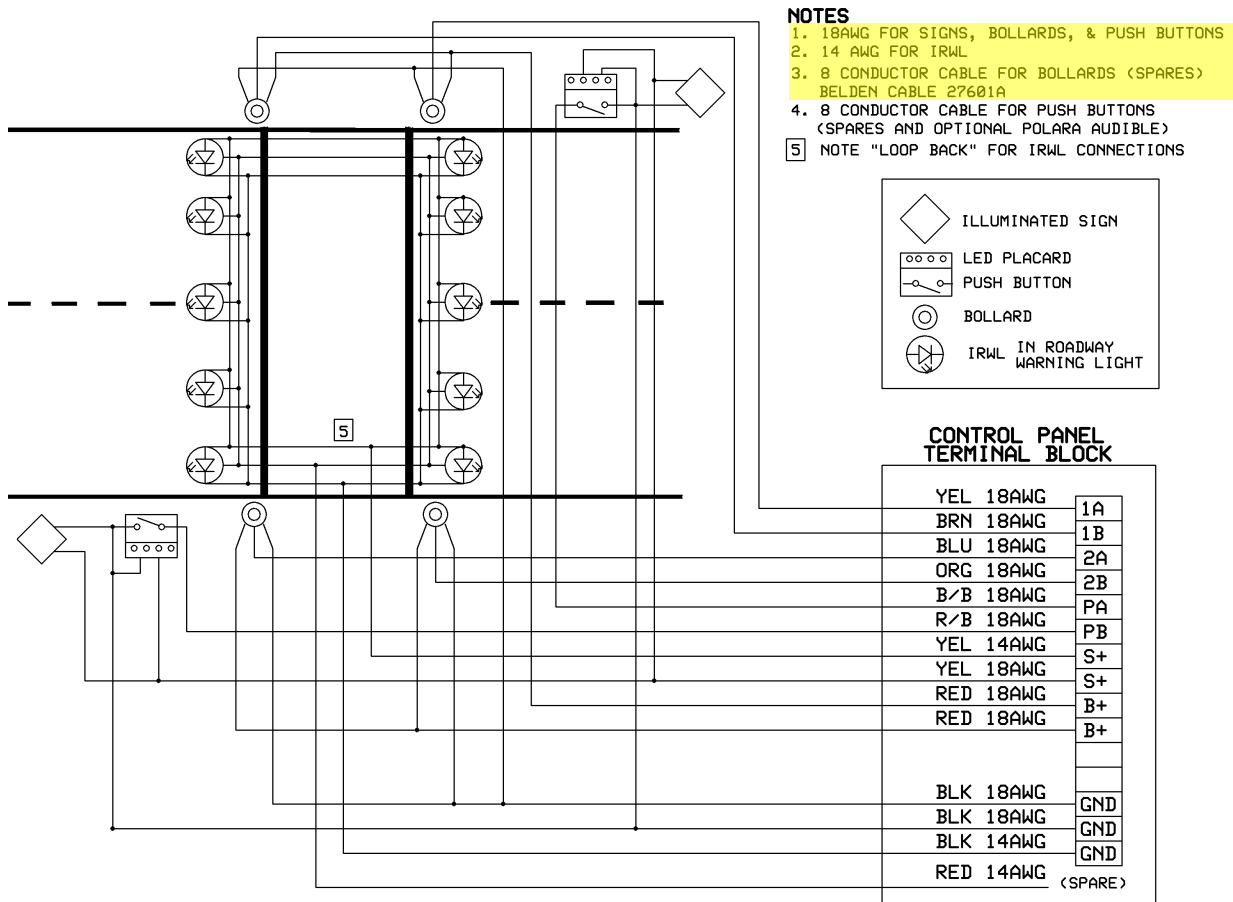

NOTE: This is a reference diagram only, connections shown are not applicable to all installations.

2.3 AC SYSTEM

2.3.1 AC ENCLOSURE DESCRIPTION

The hasp latch locking enclosure is included with the LightGuard System®. The Aluminum enclosure (UL 50 standards and NEMA 3R) & Fiberglass Enclosure (NEMA 6) contains the control panel components and can be mounted to a pole or wall. Adjustable mounting brackets are provided with enclosure (mounting hardware not included, specific hardware to be supplied by installer). The all aluminum enclosure (*no longer stock item – special request only*) comes standard with a white powder coat finish & contain knock-outs on the rear for 1/2" NPT connectors (refer to sections [2.3.2](#) & [2.4.2](#))

2.3.2 AC ENCLOSURE OUTLINE DRAWING

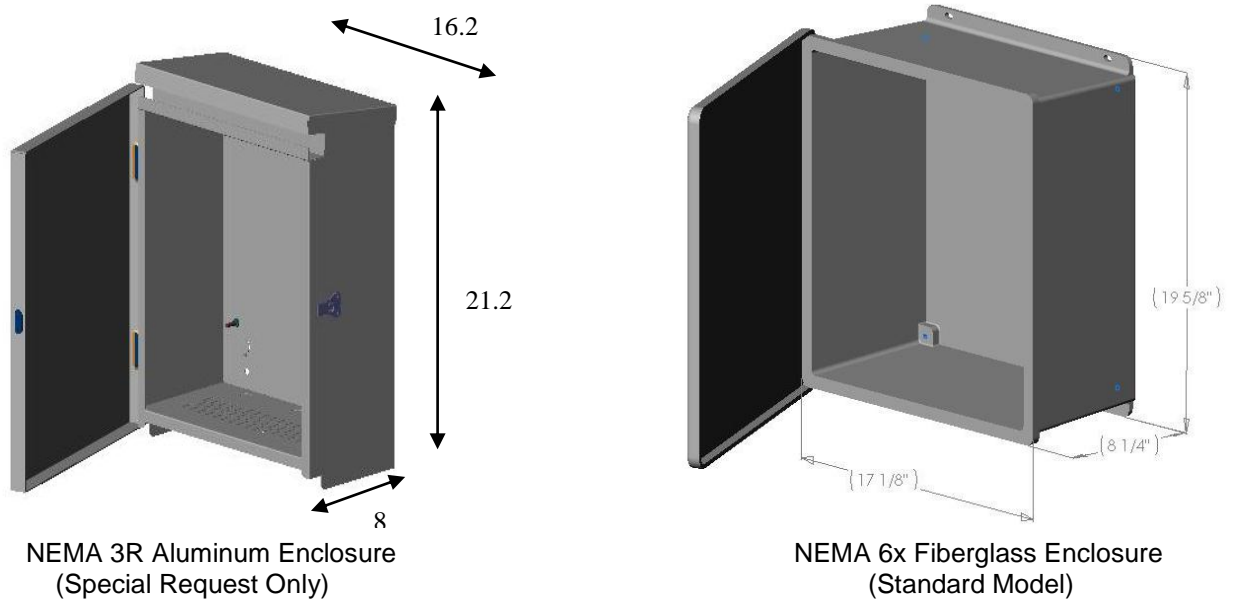

2.3.3 AC BACK PANEL LAYOUT

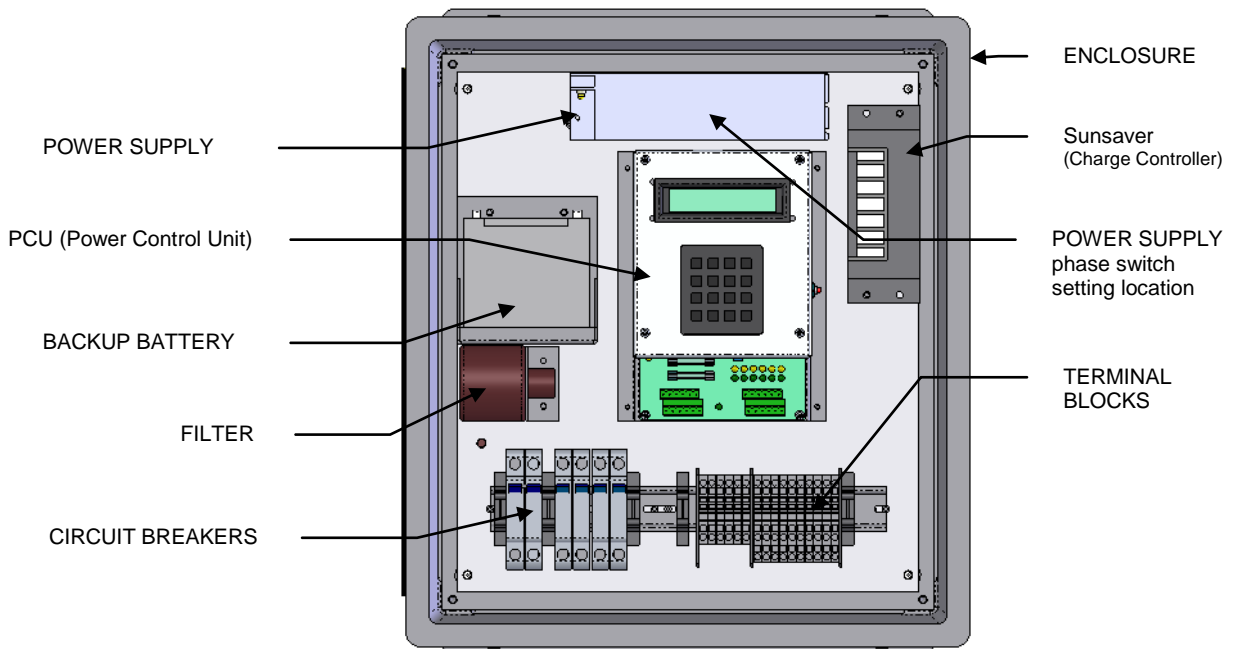

2.3.4 AC BACK PANEL SCHEMATIC

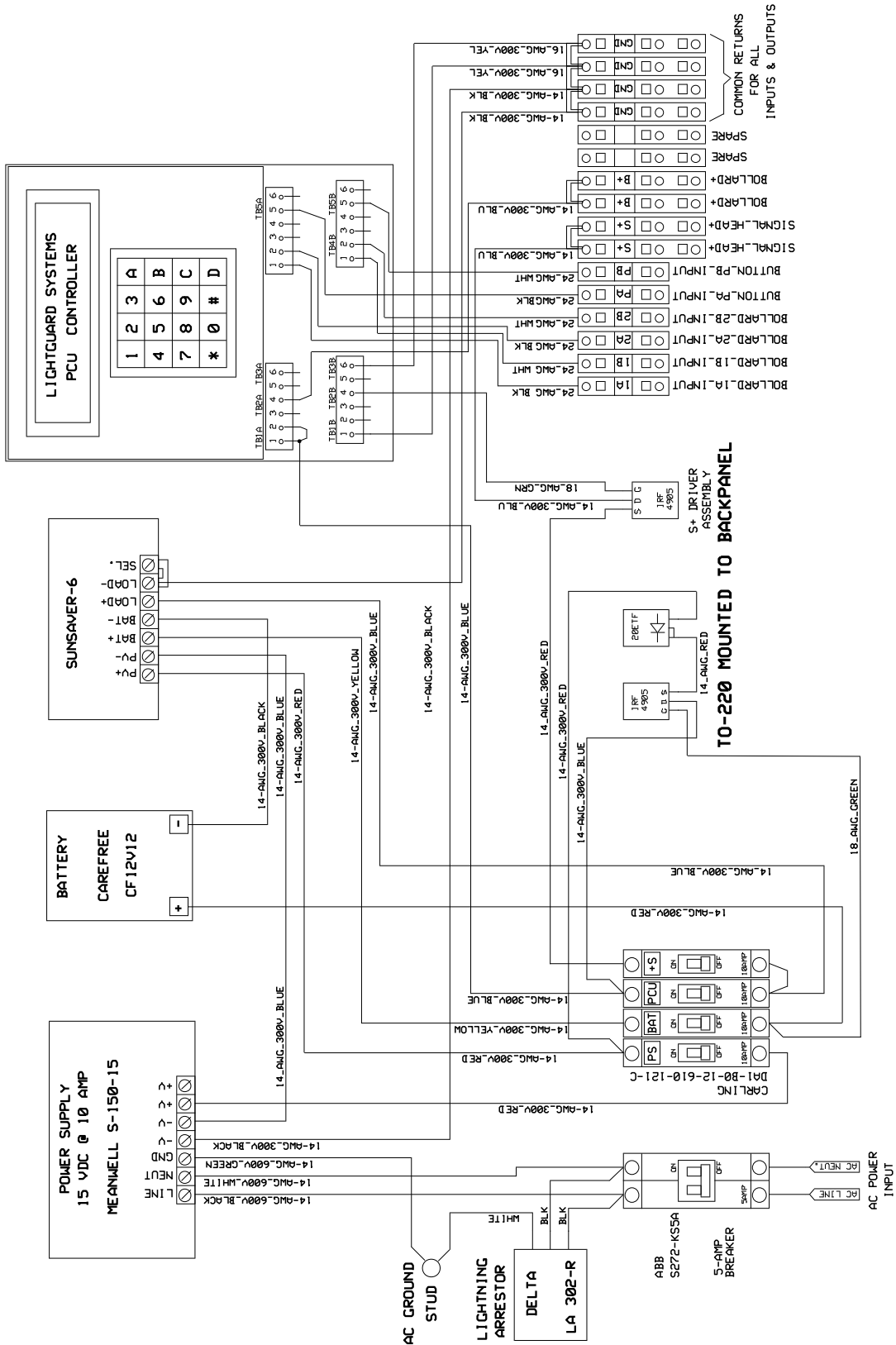

2.4 SOLAR SYSTEM

2.4.1 SOLAR ENCLOSURE

Solar powered Systems are free-standing pedestal mount or pole mount enclosures. Aluminum cabinets contain knock-outs on the rear for 1/2" NPT connectors (refer to sections [2.3.2](#) & [2.4.2](#))

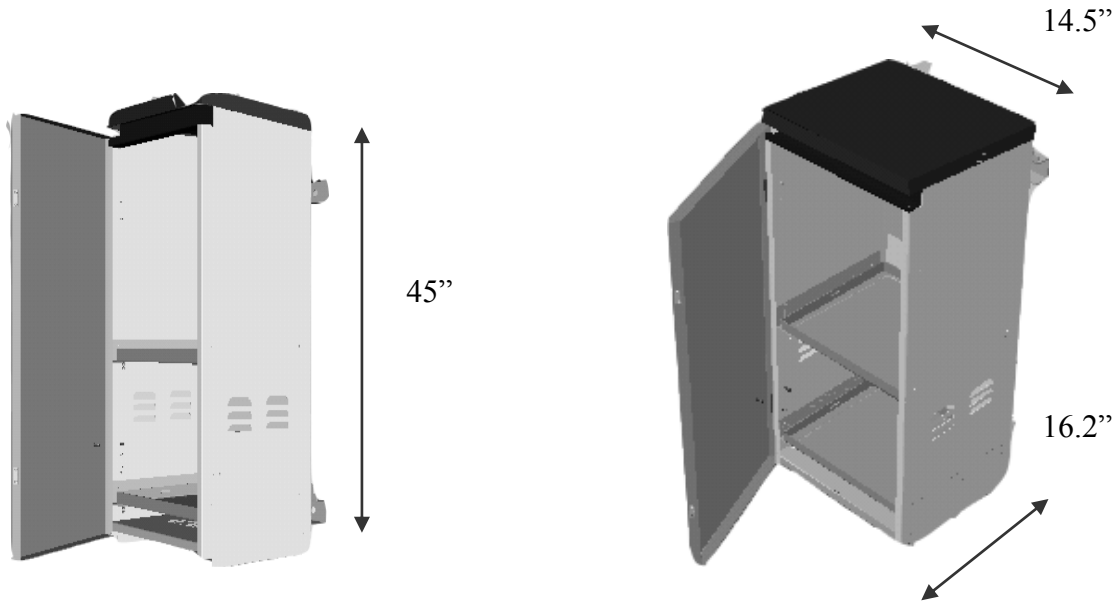

2.4.2 SOLAR BACK PANEL LAYOUT

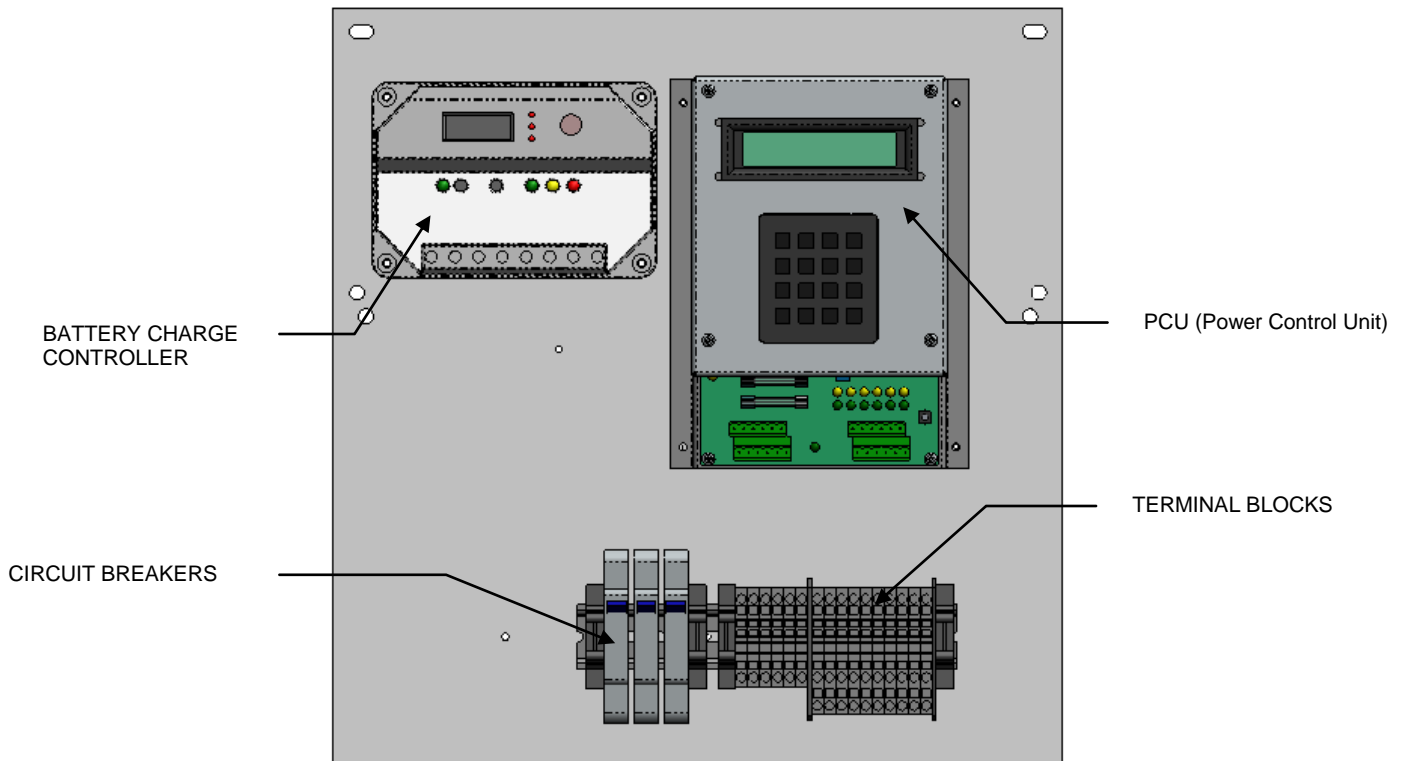

2.4.3 SOLAR BACK PANEL SCHEMATIC

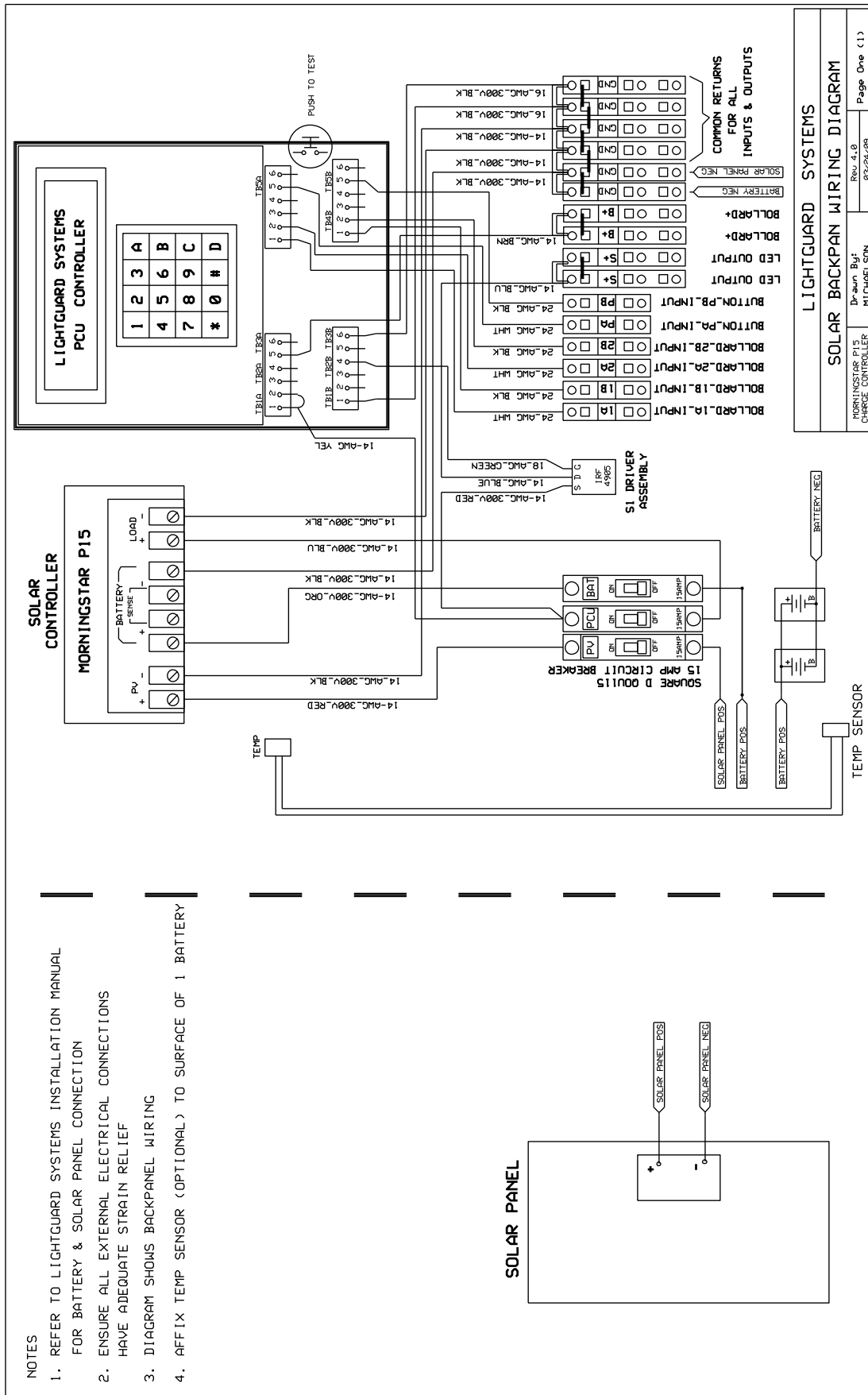

- NOTES
1. REFER TO LIGHTGUARD SYSTEMS INSTALLATION MANUAL FOR BATTERY & SOLAR PANEL CONNECTION
 2. ENSURE ALL EXTERNAL ELECTRICAL CONNECTIONS HAVE ADEQUATE STRAIN RELIEF
 3. DIAGRAM SHOWS BACKPANEL WIRING
 4. AFFIX TEMP SENSOR (OPTIONAL) TO SURFACE OF 1 BATTERY

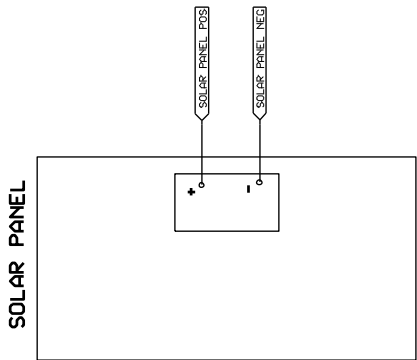

LIGHTGUARD SYSTEMS

SOLAR BACKPAN WIRING DIAGRAM

Rev. 4.0
8/2/24-09

Page One (1)

Drawn By:
MICHAELSON

MORNINGSTAR P15
CHARGE CONTROLLER

2.5 ECP SYSTEM (ECP-1 & ECP-2)

The ECP system differs from the AC & SOLAR systems in several ways. All user INPUT connections are made directly to the Flashing Unit Controller Subassembly. This system is NOT field programmable, only cross time is user selectable. Refer to section [2.5.4](#) for additional information.

2.5.1 ECP ENCLOSURE

The enclosure is a NEMA4X Fiberglass structure designed for wall or pole mounting only. Uni-strut brackets are provided with enclosure (mounting hardware not included, specific hardware to be supplied by installer). Electrical connections can be made by drilling access holes either on the bottom or the lower region on the rear of the enclosure. The enclosure has sufficient clearance to support up to one 1½" NPT connector on the rear, and several 1½" NPT connectors on the bottom. The standard enclosure color is grey.

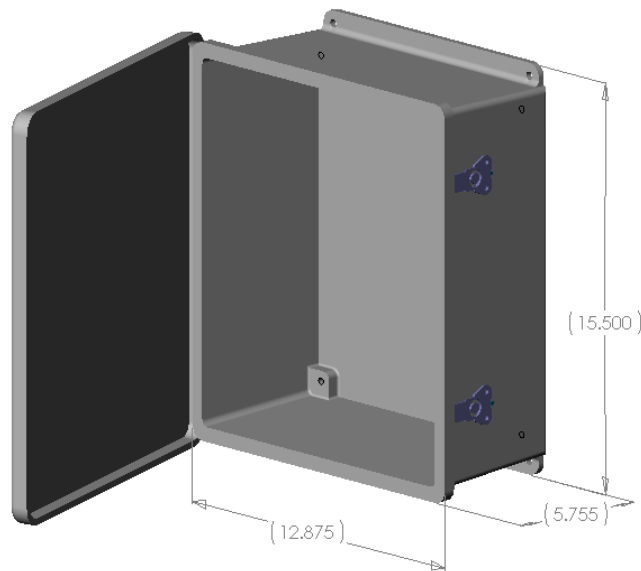

2.5.2 ECP BACK PANEL LAYOUT

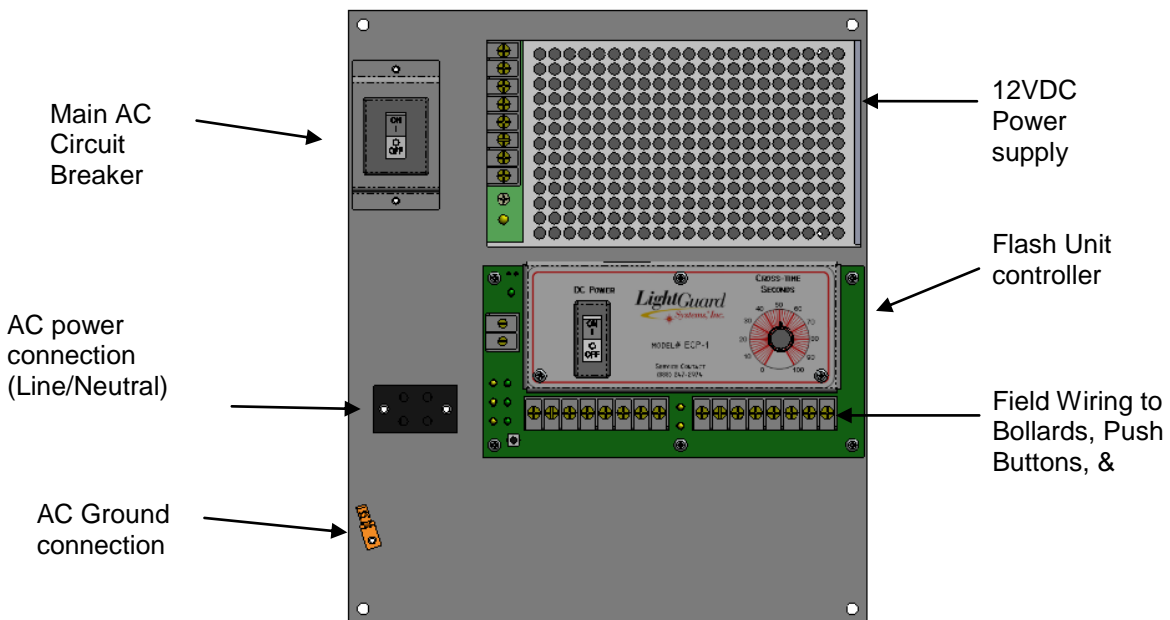

2.5.3 ECP BACK PANEL SCHEMATIC

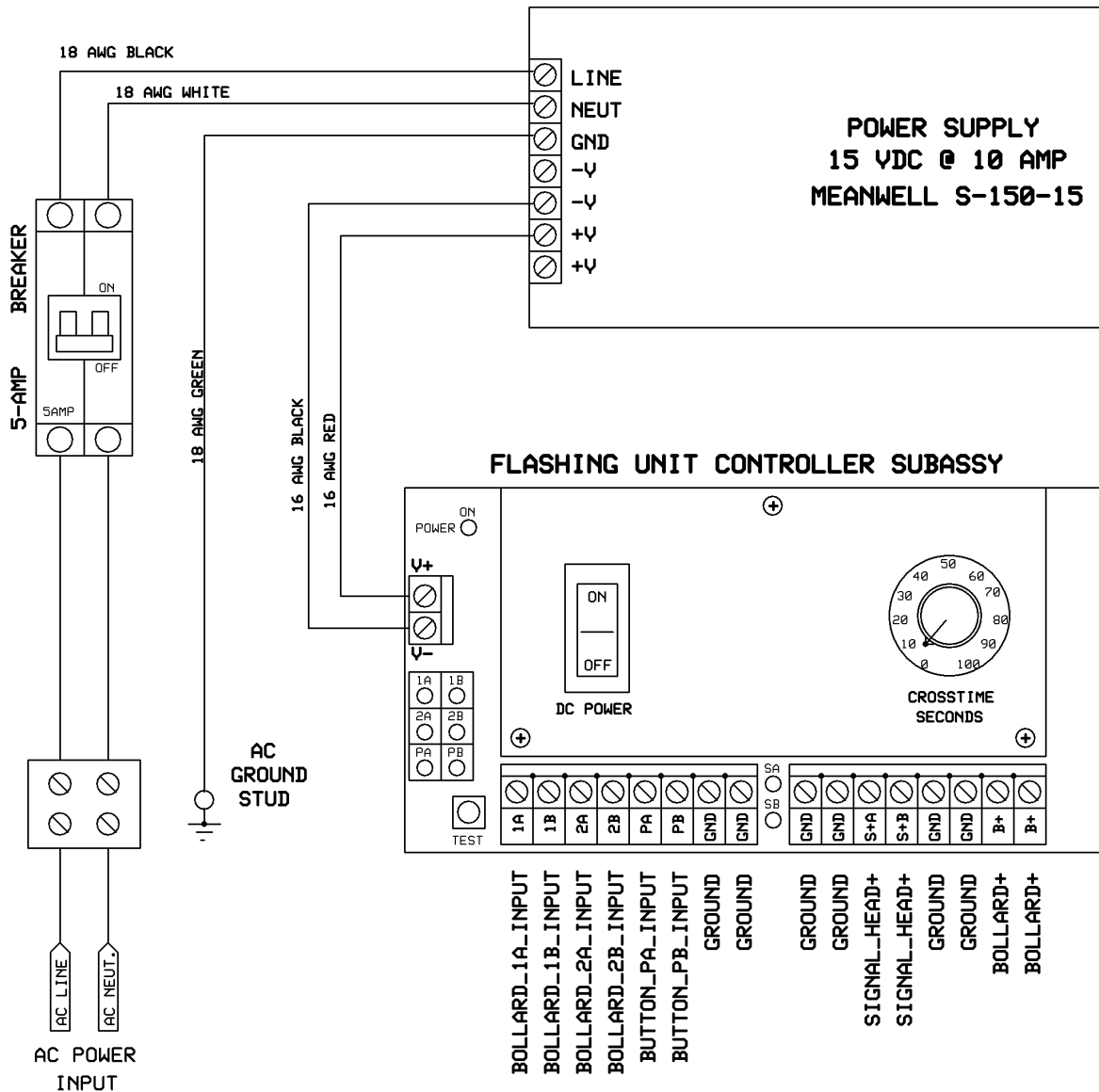

2.5.4 ECP FLASH UNIT PARAMETER ADJUSTMENTS

The ECP-1 has only one field adjustment, setting the cross time flash duration. This is set by rotating the selector knob to the number of seconds required for the system to flash once activated. Cross time can be set from 5 seconds to 100 seconds. The ECP will operate with Bollards &/or Push Buttons. Status indicator lights on the Flashing Unit Controller Subassembly show an input activation & the output flashing activation. There is also an LED to indicate that the system is energized. Lastly, there is a test button which can be used for in-cabinet testing of the ECP System.

The ECP-2 can be factory configured for 2 independent outputs each triggered from the any of the activation inputs. This system is customizable but with limitations. Contact LightGuard Systems for specific custom configurations (ie: dual color IRWL and/or DC beacons with alternating flash patterns).

2.6 ENCLOSURE POLE MOUNT DETAIL

All enclosures can be pole mounted using supplied Uni-strut brackets and appropriate hardware. The ECP, AC, & SOLAR Systems use the identical brackets.

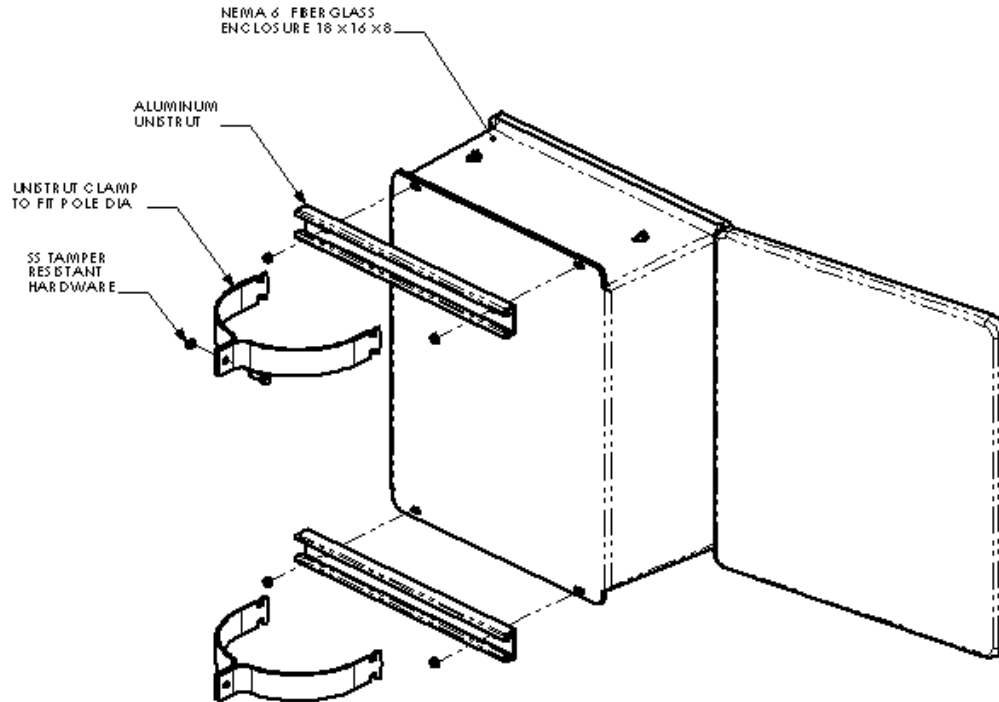

2.7 BACK PANEL ELECTRICAL CONNECTIONS

AC & SOLAR SYSTEMS

The AC & Solar back panels incorporate the system Power Control Unit (PCU), circuit breakers, and backup battery charge controller. The PCU is field programmable & controls both signaling and timing functions. The battery charge controller sequences battery charging and low voltage load disconnect.

ECP SYSTEM

The ECP back panel incorporates the ECP flash unit, circuit breakers, and DC power supply.

2.7.1 TERMINAL BLOCK CONNECTION DEFINITIONS (DC ONLY +12VDC & 0VDC)

SYSTEM INPUTS (DC ONLY)

- 1A Bollard Sensor 1st call signal side 1
 - 1B Bollard Sensor 2nd call signal side 1
 - 2A Bollard Sensor 1st call signal side 2
 - 2B Bollard Sensor 2nd call signal side 2
 - PA Normally open line from Push Button assembly closest to enclosure
 - PB Normally open line from Push Button assembly farthest from enclosure
- } Bollards closest to enclosure
- } Bollards farthest from enclosure

SWITCHED 12VDC OUTPUT (Enlighten1 pulse rate)

- S+ In-roadway Warning Signal YEL &/or RED wire depending on IRWL color 2.7.2
- S+ In-roadway Warning Signal YEL &/or RED wire depending on IRWL color 2.7.2

CONSTANT CURRENT SOURCE (12VDC Output For Use With Bollards Only)

- B+ Bollard area LED courtesy lights & Sensor Power
- B+ Bollard area LED courtesy lights & Sensor Power

DC GROUNDS (0 VDC)

- GND In-roadway Warning Signals DC Ground/Common
- GND Push Button DC Ground/Common
- GND Bollard Power DC Ground/Common
- GND LED Push Button Placard DC Ground/Common
- GND LED “Enhanced” Illuminated Pedestrian Symbol Crossing sign DC Ground/Common

2.7.2 TYPICAL ENCLOSURE “FIELD WIRING” TERMINAL BLOCK CONNECTIONS

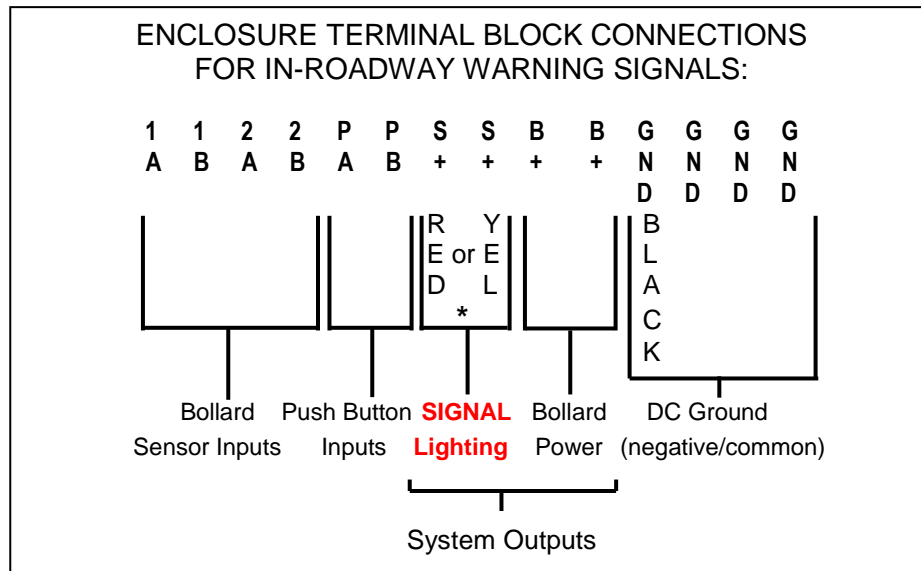

DRAWING NOT TO SCALE

NOTE: ALWAYS USE 14 AWG WIRING, TYPE RHW-2/USE-2/XLP (MAX OD .17”) APPROVED BY LOCAL AGENCY FOR IN-ROADWAY WARNING SIGNAL ARRAY HOME RUN CONNECTION. **S+ POSITIVE CONDUCTOR COLOR IS DEPENDANT ON IRWL COLOR – RED IS USED FOR RED IRWL, YEL IS USED FOR YEL IRWL.** FOR ACTIVATION MECHANISM, ALWAYS USE 8 CONDUCTOR 18 AWG STRANDED SIGNAL CABLE TO RUN FROM ENCLOSURE TO OPPOSITE SIDE OF STREET.

2.8 POWER CONTROL UNIT (PCU) DESCRIPTION

The PCU is based on a high-speed 8 bit embedded microcontroller utilizing compiled machine control language. A LightGuard proprietary software program provides effective, reliable operation allowing the user to make simple adjustments to the System parameters with a keypad and liquid crystal display (LCD).

2.8.1 TYPICAL POWER CONTROL UNIT (PCU) DRAWING

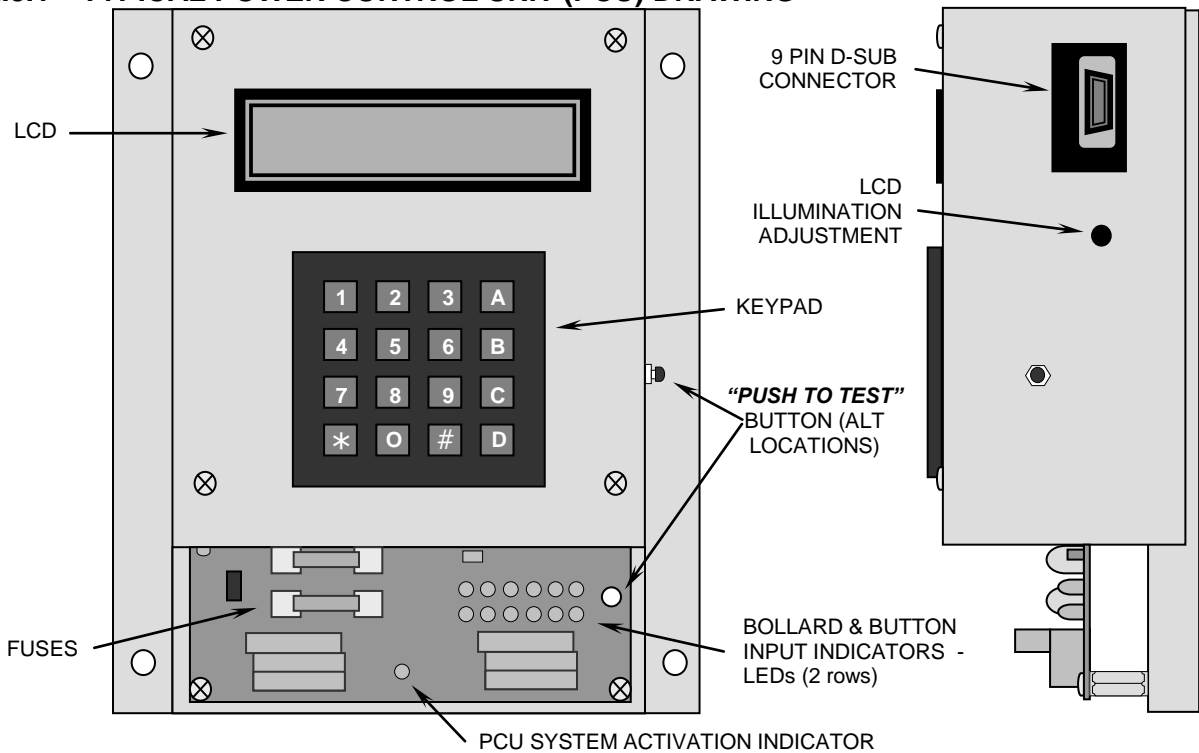

2.8.2 POWER CONTROL UNIT (PCU) PARAMETER ADJUSTMENTS

The PCU is preprogrammed with easily adjustable parameters. To operate the System manually flip all circuit breaker switches up to “ON” position. All functions are accessible from the keypad. A high-contrast liquid crystal display (LCD) provides easy read out of the settings. Pressing a key will display data, or a parameter, on the LCD. Some keys will access a list of parameters. If no change is desired, press the “#” key to escape or advance to the next parameter in that list. Pressing the “#” key can also escape from a partially entered value. Each parameter has a required number of digits. The required number must be entered or the number will default back to existing number.

The POWER CONTROL UNIT (PCU) KEYPAD FUNCTIONS TABLE describes programming the PCU using the keypad and display. Generally when a menu is accessed using one of the numeric keys, the user must complete all entries within that menu before the PCU will accept other menu parameter inputs. In many cases, the # key will act as a “next” function advancing the menu without changing the existing parameter in program memory. There is no “escape” key to undo keypad entries. If a keypad error is made, the user must complete that function menu & then repeat that function menu with correct keypad entries.

Additional notes

INITIATING THE SYSTEM – When the PCU is energized for the first time, a message should display on the LCD with instructions to contact LightGuard Systems Inc. for an **ACTIVATION CODE**. This code is used for both system installation tracking & warranty tracking purposes.

CROSS TIME - Refer to local governing agency for System activation / crossing time. Cross time is set in seconds (PCU is pre-programmed with 20 seconds as a factory default). Cross time is entered in 2 digit increments using the numeric keypad. Typical cross time duration is based on pedestrians walking speed being 2 feet to 3 feet per second. Slower pedestrians require more time than faster pedestrians. A generic formula to compute a typical cross time is to divide the length of the crosswalk (width of the street) by either 2 or 3. Cross time should be set by the installer after observing pedestrian patterns.

An example of a 60 foot long crosswalk: $60' \div 2' \text{ per second} = 30 \text{ seconds}$

FACTORY SETTINGS - The system is preset with a cross time of 20 seconds, the activation counts are set to Zero, & the date/time are set for PST, system default is Single Zone Mode.

ACTIVATION COUNT DISPLAY - When the system is in Activation Count Display Mode (LCD shows the number of activations for either bollards or push buttons), the system is in “a sleep state”. System activation WILL NOT occur (IRWL will not operate) until the activation count display mode is toggled off by pressing either 1 or 3 on the keypad respectively (software version 1.4 & earlier). When using software version 1.5 & later, activation count display mode will end after 1 minute to allow normal operation.

DOWNLOADING PCU MEMORY – PCU memory contains a limited number (approximately 65,000) of “date/time stamped” activation counts, diagnostics, & “power-up” events. The data is accessible using a computer connected to the appropriate port via RS232. Refer to addendum procedure for correct steps. This feature is available in software version 1.5 & higher.

SYSTEM ACTIVATION DISPLAY – When the system has been activated, the LCD will indicate a countdown of the remaining cross time until the Enlighten1™ flashing sequence ends. This feature is compatible with software version 1.6.7 and higher.

REMOTE COMMUNICATIONS – The PCU is designed for remote communication via the RS232 port. When operated in Terminal Mode, the remote terminal will echo many of the PCU LCD commands and text as well as some system diagnostics. Also while in Terminal Mode, the remote terminal keyboard will operate all of the PCU keypad functions. Refer to addendum procedure for remote connections. This feature is compatible with software version 1.7.0 and higher.

SINGLE/DUAL ZONE MODE – The PCU is capable of supporting both Single & Dual Zone Modes (whether or not the peripheral hardware for the Dual Zone Mode is physically connected to the PCU). The system default on “power up” is Single Zone Mode. Each time power is recycled to the PCU, the system will revert to Single Zone Mode operation. If Dual Zone Mode is required, pressing the keypad 2 will toggle into Dual Zone Mode. Single zone can be re-selected either by pressing keypad 2 again or by cycling power to the PCU. The mode can be verified (displayed on the LCD) using the keypad *. Refer to Dual Zone Installation Manual Addendum for further information. This feature is available in software version 1.7 & higher.

Custom functions available only on request

2.8.3 POWER CONTROL UNIT (PCU) KEYPAD FUNCTIONS TABLE (software v 1.7.X)

Function	Keypad Press
Clear all the Counters (Note: manually record counters prior to resetting to zero)	0 → 555
Display number of BOLLARD system activations (for Bollard pairs 1, 2, 3, & 4)	1 → # to close
Display number of PUSH BUTTON system activations (for PB's: A, B, C, & D)	3 → # to close
Set Cross Time Enter cross time in 2 digit increments up to 99 seconds. ZONE 1 - Bollards 1&2 Pushbuttons A&B	4 → 2 DIGITS
ZONE 2 - Bollards 3&4 Pushbuttons C&D (requires custom PCU)	7 → 2 DIGITS
Set Calendar & 3 Scheduled Activations (<i>Auto Time</i> 1, 2, & 3)	5
Set current Time of Day Use 4 digits, i.e. 02:30 (24 HOUR CLOCK)	# → 4 DIGITS
Set current Date Use 6 digits format mmddyy; i.e. 042903	# → 6 DIGITS
Set current Day of Week (1 = Sun, 2 = Mon, 3= Tue, etc.)	# → 1 DIGIT (1 thru 7)
1st Scheduled Activation	#
Set Auto Time 1 ON Use 4 digits, i.e. 09:30 (24 HOUR CLOCK)	→ 4 DIGITS
Set Auto Time 1 OFF Use 4 digits, i.e. 09:40 (24 HOUR CLOCK)	→ 4 DIGITS
Set Days Active press combination of 0 & 1 for each day of the week SMTWTFS - 0 for <i>inactive</i> day or 1 for <i>active</i> day	→ 7 DIGITS (0 or 1)
2nd Scheduled Activation	#
Set Auto Time 2 ON Use 4 digits, i.e. 12:30.(24 HOUR CLOCK)	→ 4 DIGITS
Set Auto Time 2 OFF Use 4 digits, i.e. 12:40 (24 HOUR CLOCK)	→ 4 DIGITS
Set Days Active press combination of 0 & 1 for each day of the week SMTWTFS - 0 for <i>inactive</i> day or 1 for <i>active</i> day	→ 7 DIGITS (0 or 1)
3rd Scheduled Activation	#
Set Auto Time 3 ON Use 4 digits, i.e. 15:30.(24 HOUR CLOCK)	→ 4 DIGITS
Set Auto Time 3 OFF Use 4 digits, i.e. 15:40 (24 HOUR CLOCK)	→ 4 DIGITS
Set Days Active press combination of 0 & 1 for each day of the week SMTWTFS - 0 for <i>inactive</i> day or 1 for <i>active</i> day	→ 7 DIGITS (0 or 1)
Pedestrian Detectors in/out Service turn power on or off to all Bollards using keypad 6 to alternate between on & off	6
Alternate Cross Time (custom application)	7A → 2 DIGITS
Single/Dual Zone mode toggles software between single zone and dual zone modes. The software MUST be in Single Zone mode for all inputs to activate ZONE ONE.	2
All Outputs on Constant Blink using keypad 9 to alternate between on & off	9
Display Software version	*

2.8.4 POWER CONTROL UNIT (PCU) DETAILED KEYPAD INSTRUCTIONS (software v 1.7)

The following detailed instructions for using the keypad and display is organized by function. The text on the left describes the key-presses and programming process step, and the text on the right is what is actually shown on the PCU display.

2.8.4.1 1ST TIME START UP

To activate the system for the 1st time, a start code is required. This start code can be obtained by contacting LightGuard Systems using the phone number shown in the display.

1 st time start up Display	Call 1-888-247-2974 or Enter Start Code:
Key-in the correct 3 digit start code. Keying in the 1 st digit will overwrite the existing display. Each successive digit will overwrite the previous digit. Example shown is typing in Start Code 123	1
	2
	3

2.8.4.2 DEFAULT DISPLAY

The Default Display will be visible at all times unless another menu is currently activated. After a short period of inactivity, the system will generally revert back to the Default Display (exceptions are constant flash mode & fault conditions) to accept keypad inputs.

The example shown is April 1 2009 @ 9:51A	LightGuard Systems 04/01/09 09:51:05
---	---

2.8.4.3 SOFTWARE VERSION

The system will show the software version & zone mode from the internal micro controller.

To display the software version Press *. The example shown is version 1.7.4 in Single Zone Mode	SW version 1.7.4 Single Zone Mode
---	--------------------------------------

2.8.4.4 CHANGE CROSS TIME

The Factory Default Cross Time is set to 20 seconds.

To Set Cross Time for Zone 1, Press 4 to open the menu & then 2 digits to set new time (example 15 sec)	Zone 1 Cross Time=20 New Time is 15
To Set Cross Time for Zone 2, Press 7 to open the menu & then 2 digits to set new time (example 25 sec)	Zone 2 Cross Time=20 New Time is 25

2.8.4.5 CLEAR ALL THE COUNTERS

To Clear all the counters: press 0 to open the menu	Press 555 to Zero Counters & Log: █
Then press 555	Press 555 to Zero Counters & Log: 555
Clear counters Message will briefly display	Counters are Set to Zero

2.8.4.6 DISPLAY BOLLARD ACTIVATION COUNTS

To Display the number of bollard system activations (bollard pairs 1, 2, 3, 4), press 1 to open the menu. The example shows 12,345 call signals received from each of the bollard pairs.	#1= 12345 #2= 12345 #3= 12345 #4= 12345
--	--

2.8.4.7 DISPLAY PUSH BUTTON ACTIVATION COUNTS

To Display the number of push button system activations (buttons A,B,C,D), press 3 to open the menu. The example shows 12,345 call signals received from each of the bollard pairs.	#A= 12345 #B= 12345 #C= 12345 #D= 12345
---	--

2.8.4.8 BOLLARD POWER ON/OFF

The power to the bollards can be toggled off/on using the keypad.

To toggle power off/on to the bollards (both the sensors & courtesy lights) press 6	Ped Detectors OUT OF SERVICE
To toggle power on/off to the bollards (both the sensors & courtesy lights) press 6	Ped Detectors IN SERVICE

2.8.4.9 CONSTANT FLASH

The flashing outputs can be set to activate continuously.

To set outputs on constant flash, press 9. This message will display until 9 is pressed again or power is recycled	Constant Flash Mode Press 9 to End
--	---------------------------------------

2.8.4.10 CALENDAR SETTING

The calendar menu is linked / integrated into the auto-time activation feature menu. Once this menu is initiated, there is no “back” capability. If a mistake is made in keying, either finish the menu sequence & then repeat the entire process with correct keying or turn the power off/on for system reset. In general, press * to advance the menu without having to input prompted data.

To set the internal calendar press 5 to open the menu	# = yes / * = no Set Time? █
Press # to enter a new time in 24 hour clock. Example showing current time 13:11 (1:11 PM)	Time: 13:11 NEW(24Hr.) █
Example showing current time 13:11 (1:11 PM) changing to 0953 (9:53AM)	Time: 13:11 NEW(24Hr.) 0953
New Time Message will briefly display	TIME: 09:53
Press # to enter the date	# = yes / * = no Set Date? █
Enter the date using 6 digits MMDDYY format	Date: 04/01/09 NEW(MMDDYY) █
Example showing current date April 1 2009 changing to January 1, 2010	Date: 04/01/09 NEW(MMDDYY) 010110

New Date Message will briefly display	Date: 01/01/10
Press # to enter the day of the week	# = yes / * = no Set Day? █
Enter a number to represent the day of the week using a single digit 1 through 7	Day # is: 6 NEW # (SUN=1) █
Example showing current day of the week is Friday changing to Wednesday	Day # is: 6 NEW # (SUN=1) 4
New Day Message will briefly display	Day: 4
The AutoTime setting prompt will display. Press * to advance the menu without setting AutoTime. Press # to set AutoTime.	# = yes / * = no Set Zone 1 AutoTimes

2.8.4.11 AUTO TIME

After the calendar has been set, the menu will continue for setting up automatic activations at specific times. This feature is referred to as Auto Time. There are 3 different Auto Time settings available. To bypass this part of the menu, pressing * will advance thru the successive prompts until the Default Display is shown. To program the controller for Auto Time, follow the steps below.

Press # to set up Automatic Activations based on schedule. This example shows how to program the system for Zone 1 activations from 7:00A-8:30A on Monday Wednesday & Friday. Note that the same sequence is used for programming Zone 2.	# = yes / * = no Set Zone 1 AutoTimes
Auto Times Setting Message will briefly display	Zone 1 AutoTime Settings
Then the prompt to Enter a Start Time will display	Time 1 ON: 00:00 NEW Time 1 ON: █
Set a Start time for 1 st Auto activation to 7:00A	Time 1 ON: 00:00 NEW Time 1 ON: 0700
New Start Time Message will briefly display	Time 1 ON: 0700
Then the prompt to Enter a Stop Time will display	Time 1 OFF: 00:00 NEW Time 1 OFF: █
Set a Start time for 1 st Auto activation to 8:30A	Time 1 OFF: 00:00 NEW Time 1 OFF: 0830
New On Time Message will briefly display	Time 1 OFF: 0830
Then a prompt will appear to program the days this scheduled activation will occur.	Days Active1:0000000 NEW SMTWTFs: █
Keying in a 1 means that auto time is set for that day, a 0 means no auto time that day. The example shows auto times for Monday Wednesday & Friday only.	Days Active1:0000000 NEW SMTWTFs: 0101010
Then a message briefly displays showing the days that have been set to activate.	Days Active1:0101010

The menu process steps for Auto Time will repeat for EACH of the other 2 auto time activations. These process steps can also be repeated for Zone 2 as required / if applicable.

3 IN-ROADWAY WARNING SIGNAL (IRWL)

3.1 GENERAL DESCRIPTION

The LightGuard System® In-Roadway Warning Light (IRWL) LED light fixture is made of a high strength plastic composite. It is designed for mounting into a base plate assembly that is permanently attached to the roadway. This allows for any in-roadway warning light fixture that may become damaged, or inoperable for any reason, to be easily repaired with a plug-in replacement.

IN-ROADWAY WARNING LIGHT (IRWL) TYPE-9X ASSEMBLY

General Performance Specifications

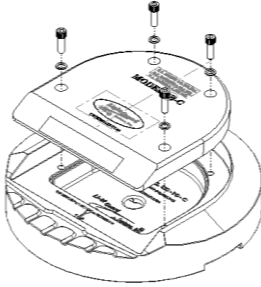
Parameter	Value	Typical Mounting	Base Plate Compatibility
Visibility	± 22.5° Horiz +10° Vert		SD-10C (composite) CHS-14 (steel)
Operating Temp	-20° to +80°C		<h5>Available Models</h5> LGS-9X-1 (Red) LGS-9X-2 (Amber/Red) LGS-9X-3 (Amber) LGS-9X-4 (White)
Operating Voltage	9VDC to 15VDC		
DC Current @ 12VDC	0.1 Amps		
Avg Power Dissipation	1.5 watts		
Luminous Intensity	252,000 mcd		
Material	Polyurethane/Nylon		
Housing Color	Black		

3.2 MAJOR CONSIDERATIONS FOR LIGHTGUARD SYSTEM IRWL INSTALLATION

There are a number of basic considerations when determining the location and alignment direction of each in-roadway module for any given installation site. These items should be considered during the installation procedure for the LightGuard in-roadway warning system. Be sure to have enough specified wire/cable, 2-part epoxy, and saw cut filler (loop detector type filler) ON SITE BEFORE BEGINNING INSTALLATION.

3.2.1 DISTANCE OUTSIDE OF, AND AWAY FROM CROSSWALK STRIPES

The installer should measure and be certain to keep the distance at least 18” from the outward edge of the crosswalk. In general, greater distances can be used without any noticeable difference to the motorist. However, no greater distance than ten (10) feet is recommended by MUTCD standards. If required by a specific circumstance, (i.e., grade or advance curve warning layout) placement may necessitate an authorized deviation, using sound engineering judgment (thereby not conforming to MUTCD standards).

3.2.2 LOCATION OF EACH INDIVIDUAL IRWL MODULE

Each in-roadway LED module should be located in a position that will be directionally visible to the approaching motorist (from their viewing position at the wheel usually 200’ to 400’ in advance of the crosswalk) allowing sufficient time to recognize and react to the warning lights upon activation.

3.2.3 PATTERN

The pattern or layout should follow the recommended configurations that have been tested and proven effective for the type of crosswalk for which the system is being used. The MUTCD - Manual for Uniform Traffic Control Devices 2009 chapter 4N (<http://mutcd.fhwa.dot.gov/hlm/2009/part4/part4n.htm>) defines the authorized use & application of IRWL. For best practice; one module on the outside travel lane edge of each parking lane or bike lane (stay out of bike/parking lanes), one module on the center divider lane or line, and one module in each travel lane approximately under the location of each vehicle’s license plate, (or centered between the tire paths of the travel lane). The “geographic” center of the lane may not be the appropriate location as vehicular traffic tends to travel “off center” of any

given marked lane. The idea is to minimize the frequency of tire impact to the in-roadway modules by placing them outside of the predominant vehicle tire wear pattern. With a raised median strip, the module that is usually placed on the centerline or lane should be installed on the far left of the approach lanes next to the raised median curb or barrier. For maximum or higher level needs, an optional addition of one module on each lane delineation line may be considered. Placement should be in accordance with MUTCD. Examples showing optional & required placement for California MUTCD can be found via <http://www.dot.ca.gov/hq/traffops/signtech/mutcdsupp/pdf/camutcdraftrev/4L.pdf>.

3.2.4 AIMING POINTS

The light beam view path of the modules should be determined by the local traffic engineer or responsible agency for the purposes of reaching the motorists viewing point 200'-400' in advance of the crossing (refer to section 3.7 for aiming and alignment). Generally, the layout provides for the modules in the approach travel lanes to be aimed straight down the approaching motorist's viewing path. The parking lane units (from the left and right sides) should also be aimed or aligned toward a "control point" approximately 200' to 400' in advance of the crossing, and should also converge at the approaching motorist view path. This would have the outside units canted slightly inward toward the center of the lanes to that point. The units on the center line and opposing travel lanes will be canted slightly toward the approaching motorist travel lanes to those "control points" that will allow the approaching motorist the best view of the light source. Again, generally from 200' to 400' feet away depending upon the approach speeds at the particular location. Curved approaches will require a greater degree of analysis to provide the maximum benefit.

3.2.5 SAW CUT FOR WIRING AND IRWL MODULES

The saw cut for wiring should follow the manual for depth and width to accommodate the necessary wiring and tray cable for the installation. As a general rule this averages 3/8" - 1/2" wide cut approximately 2 1/2" deep (should be below core drill depth). Operational component connections from PCU to across the street can be pulled to terminal boxes for easy access connecting activation mechanisms and other active LED components using standard type wire. Ensure that the saw cut makes a complete loop through all IRWL locations (refer to wiring diagram section 3.6.2).

3.2.6 DEPRESSION CUTS FOR LIGHT MODULE (IRWL SIGNAL HEAD) BASE PLATES

The depression cuts for the base plate assemblies can be accomplished in a number of ways. Most contractors prefer core drilling or a chip hammer. A flat bottom "Grinding Core Drill Bit" is available to improve efficiency (refer to section 1.7). After determining the location and aiming direction of that particular light module, core or chip out hole approximately 1 3/8 inch (+/-1/8 inch) deep see reference dimension table 3.2.6.1 A clean "corner" is desired at the bottom (flat bottom, vertical edges). Trim interior surface to proper depth, clean and prepare for epoxy. *The size of the depression cut is VERY important. If the depression cut is too deep or the OD is too large, then excess epoxy will be required for securing to the roadway. If the depression cut is too shallow, the base plate will protrude above grade. If the depression cut OD is too small, insufficient epoxy will prevent the base plate from being permanently affixed to the roadbed.*

3.2.6.1 REFERENCE DIMENSIONS FOR BASE PLATE MOUNTING TO ROADWAY

Base Plate Model	Base Plate Material	Base Plate OD - Outside Diameter	Base Plate Height	Recommended Depression Cut Hole Diameter	Recommended Depression Cut Hole Depth
CHS-14 revH (& after)	Steel	13 3/4"	1 3/8"	14"	1 1/2" max
SD-10C	Composite	9 7/8"	1 3/8"	10" (min)	1 1/2" max

3.2.7 EPOXY

Be sure to have enough wire/cable, SPECIFIED 2 part epoxy (**Bondo 7084 Piezo/Traffic Sensor Sealant** available at 800-622-8754 or by LGS upon request), and saw cut filler (loop detector type filler specified by local regulations) ON SITE BEFORE BEGINNING INSTALLATION. AFTER ALL WIRES

ARE IN PLACE IN THE WIRE CUTS, trim the wire to a suitable length to work with for wiring the base plates. Using duct seal or equivalent, create a temporary “epoxy dam” [section 3.5.3](#) at the interface where the saw cuts enter/exit the depression cut area. The temporary epoxy dam prevents epoxy from flowing from the depression cut into the saw cut.

Remove plastic thread protectors from threaded holes in base plate. Temporarily install socket head cap screws into threaded holes (approximately 3-4 turns) in order to use the screws for base plate leveling. Slip the wire through the center hole and “stand” the base plate on end “ready” to place into the depression. Thoroughly mix the appropriate type of epoxy for use in the base plate depression cut. Place an appropriate amount of 2 part epoxy in the depression (sufficient to completely seal bottom and rise around outside edges of the base plate when pushed into place). To insure a proper moisture seal, place the initial “glob” of epoxy in the center of the depression, move (or wiggle) wires around in the epoxy to attain wire seal, then push material to the outside edges and set the base assembly in place. The base plate should be aimed and level (use the temporarily installed screws to elevate the base plate if required during leveling) before epoxy is allowed to set-up properly. Note: If the depression is for some reason cut too deep, a “few” small rocks, pebbles or BB’s can be used to maintain a proper height. It is best to have the epoxy surround the base plate edges approximately level with the surface. Epoxy working life is approximately 10 minutes depending upon ambient temperature. After this duration, the base plate can’t be moved. Allow epoxy time to fully set, generally 20 to 30 minutes, prior to installing IRWL.

3.2.8 WIRES

Be certain that wire (ref [section 1.6](#)) type RHW-2/USE-2/XLP (**MAX OD 0.17”**) is the correct size and type for in-roadway modules, and activation mechanisms (bollards &/or Pushbuttons) for single run across street as recommended. Pull and cut 14 AWG wires to appropriate length. DO NOT STRIP INSULATION from IRWL wire. Connect to molded plug connector provided in base plate assembly using provided Scotchlok Self-Stripping Pigtail Connectors-crimp to seal (see [section 3.6](#)).

3.2.9 SIGNAL HEAD INSTALLATION

Using compressed air, remove dirt and all debris from base plate cavity. Ensure that mounting screw threads are clear. Place duct seal or plumbers putty onto the base plate in the region under the signal head around the outside edge perimeter (refer to [Figure 1](#)) to minimize the potential for moisture entering the base plate. Plug pig-tailed base plate cable electrical connector (RECEPTACLE) into IRWL cable electrical connector (PLUG). Note appropriate alignment for 3 pin connector. Check for proper “O” ring placement and attach signal head to base using **SOCKET HEAD CAP SCREWS** with **LOCK WASHERS** and **FLAT WASHERS**. Tighten using an **INCH POUND TORQUE WRENCH**.

Composite Base plate: Recommended torque value is **not to exceed 4 foot pounds** (48” pounds) – **NO TIGHTER**. Hand tightening with a standard Allen wrench is also acceptable. WARNING – the composite base plate is very sensitive to this procedure, as damage to the threads may occur if tightened over 4 foot pounds.

Check for even contact and snug fit with base plate top surface. Place additional duct seal or plumbers putty into the gap between the base plate and the signal head and into the counter bore holes for the socket head cap screws to minimize the potential for moisture or debris from entering the base plate (refer to [Figure 2](#)). Check for LED light module operation and move on to next unit.

NOTE: It is IMPERATIVE that these steps be followed when installing the signal heads. Failure to do so voids the manufacturer’s warranty. It is highly recommended that within 30-45 days after initial installation, that the heads be re-checked to verify that the 4 foot pounds of torque has been maintained.



Figure 1



Figure 2

3.2.10 NEW ROAD SURFACE CONSTRUCTION INSTALLATIONS

If site is new construction, conduit under the roadway surface and knockout templates (to achieve base plate depression excavation for installation) is an option for the installer/contractor. This will avoid or minimize saw cutting into new roadway surfaces. Plywood cutouts or similar knockouts to match the base plate assembly size may be utilized in preparation for the installation of the base plates upon completion of the roadway surface. Precise engineering must be exercised to insure proper placement and alignment of the in-roadway modules on the lane lines and travel lanes once the work is completed. A separate conduit is recommended for the single run of tray cable across the street.

3.3 CONCRETE INSTALLATION PROCEDURE

The following information is a basic guideline for installing LightGuard Systems In-Roadway Warning Lights at locations where new concrete is to be poured.

Conduit must be installed. It should be placed at least 3" to 4" below the surface of the roadway (or as required by local regulations). The single $\frac{3}{4}$ " hole in the center of the base plate can be enlarged (to approx. $2\frac{1}{2}$ " diameter) in order to insert two $\frac{3}{4}$ " PVC conduits connected to 90° elbows up into the base plate wiring cavity. Alternatively, a single $1\frac{1}{2}$ " to 2" diameter metal or PVC conduit can be used with a TEE connection stub that extends at least 1" above the surface (after concrete is poured) for pulling wire loops through TEE's. This is installed at each location where an In-Roadway Warning Light Base plate will be placed. Minimum recommended conduit is $\frac{3}{4}$ " PVC to comply with NEC 14AWG type RHW-2/USE-2/XLP conductors.

Use a circular wooden plug or equivalent ($1\frac{1}{2}$ " thick x approx $10\frac{1}{8}$ " diameter for SD-10 Base plate or 14" diameter for CHS-14 Base plate) with a center hole having a diameter just larger than the conduit stub(s) protruding up from the road bed as a concrete forming tool (ref section [3.2.6.1](#)). The plug center hole diameter should be minimum $\frac{1}{8}$ " smaller than center hole in base plate to ensure subsequent base plate seating. The plug is placed over the conduit stub (or elbows) during the concrete pour to create a depression form for installing the base plate when concrete is dry.

After the concrete is dry, the wooden plug is removed & the base plate is affixed into the road (ref section [3.2](#)). Excess concrete around the conduit should be removed to allow epoxy to bond the conduit to the base plate at the center hole. The extended conduit can then be cut flush to the inside surface of the base plate. Remove any excess epoxy &/or concrete from the base plate. After conductors are terminated, the exposed portion of the conduit opening should be filled with duct seal to minimize the potential of moisture or contaminants from entering the conduit.

3.4 IRWL SIGNAL AND BASE PLATE INSTALLATION GUIDELINES

NOTE: Correct Placement of Bases is CRITICAL to System Performance

Step 1 - Determine placement and site angles of in-roadway warning signals to intersect at optimum driver viewing zone as specified by Improvement Drawings (See Section [3.7.1](#)). Signal assemblies can be manually aimed, but laser site method is preferred.

Step 2 - Provide depression cut-out for base plates approximately 1 3/8 inch (+/- 1/8 inch) inch deep on concrete or asphalt. Depression cut-out should be .25 to .5 inches, slightly larger than base plate. Depression cut-outs should be level, or even, to conform to the existing approach grade of the roadway.

Step 3 - Perform saw cuts using pavement cutting device in accordance with predetermined layout to facilitate hook-ups through bottom of base plate to terminal connection points. Cuts to be 0.5 inch width in accordance with the CA Standard Plan ES-5A, or local standards, with a depth of 2 – 2½ inches for direct burial of wire. (See Sections [3.5.1](#) and [3.5.2](#))

Step 4 - Dig out for traffic electric hand hole boxes and install boxes for wiring access points at predetermined locations in accordance with the CA Standard Plan ES-5E, or local standards.

Step 5 - Install all necessary wire to predetermined connection points and lay in cleared roadway cuts. Using duct seal or equivalent, create a temporary “epoxy dam” [section 3.5.3](#) at the interface where the saw cuts enter/exit the depression cut area. The epoxy dam will temporarily hold down the wires & simultaneously dam the core drill area to prevent flow of epoxy back into the saw cut.

Step 6 - Check for proper site distance angles and level depth of base plate (See Sections [3.7](#), [3.5](#) and [3.2.4](#)). Mark alignment on roadway for base plate focus direction. Top of base plate (circumferential edge shown in section [3.5.1](#)) should be flush or slightly below (less than .10 inch) roadway surface AND free from excess adhesive (See section [3.5](#)).

Step 7 - Mix only enough 2-part epoxy (BONDO 7084) for 2 to 3 base plates, since Epoxy working life is approximately 10 minutes. Surfaces should be cleaned of dirt or debris, and dry before applying adhesive. Ensure that wires are vertical in the center of the depression cut. Pour epoxy into depression cut (approximately ¼” depth). Pull wire through center hole in base plate. Secure base plates to roadway surface by pressing the base plate into the epoxy in the depression cut. Ensure that epoxy flows around the outside diameter of the base plate and slightly around the wires emerging from the center hole of the base plate, but DOES NOT fill the base plate. Ensure that epoxy fills outside diameter of base plate up to grade level. Ensure that the base plate is aligned with the mark made in step 6 above (See section [3.5](#)) and is aimed vertically toward the zone of convergence *prior to epoxy curing*. Allow minimum of 30 minutes of epoxy cure time prior to moving wires for connecting pigtail gel plugs (section. [3.6](#)).

Step 8 - Allow minimum of 1 hour cure time (above 70°F & 2 hours if colder temperatures) before opening traffic lanes to vehicles travelling over recently epoxied base plates. Signal heads can be secured to base plates as soon as epoxy has sufficiently hardened. ***NOTE: Temperature is critical.***

Step 9 - Secure in-roadway warning signal to base plates using socket head cap screws using Allen Wrench or equivalent. Socket head cap screws are to be coated with anti-seize compound for maintenance purposes to ensure that screws can be removed after exposure to the environment & additionally contain an embedded nylon thread-lock bead to prevent the screws from backing out while exposed to the roadway environment.

Step 10 - Complete “dress-up” saw cuts with Loop Sealant etc. DO NOT use Loop Sealant to “dress up” outside diameter of base plate to level epoxy surface with grade.

3.5 IRWL SAW CUT CROSS-SECTION DIAGRAMS

3.5.1 FRONT VIEW - PARALLEL TO ROADWAY (SD10-C BASE PLATE SHOWN)

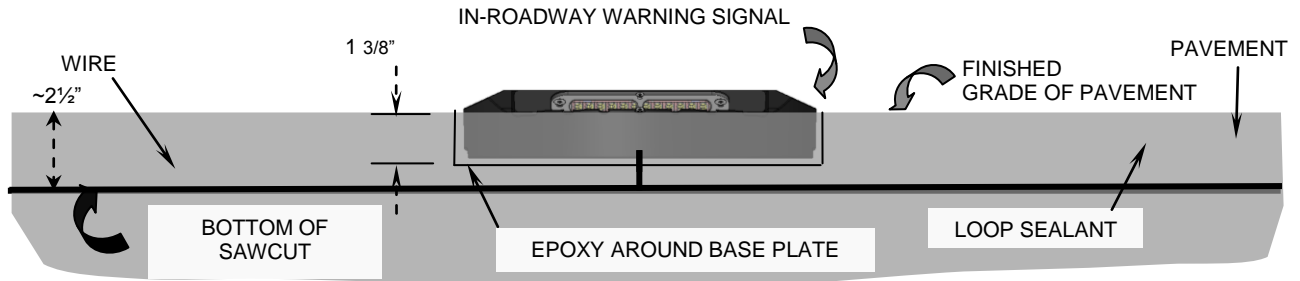

3.5.2 SIDE VIEW (PERPENDICULAR TO ROADWAY)

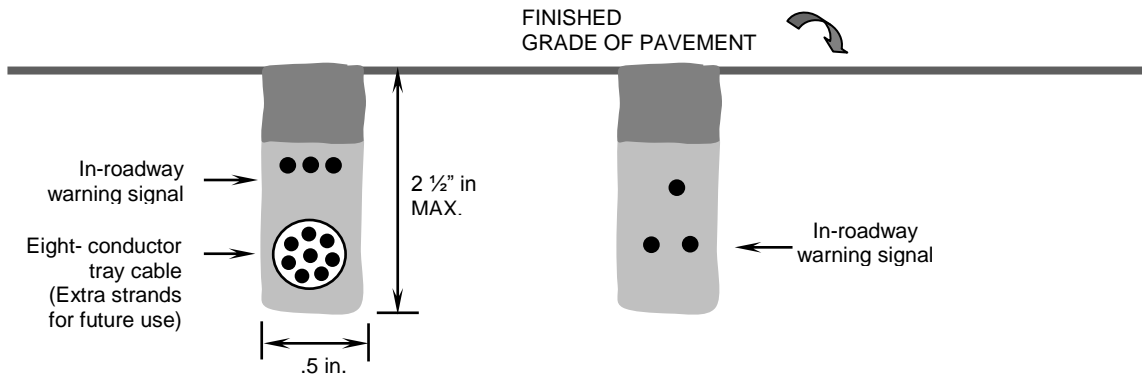

DRAWINGS NOT TO SCALE

Loop sealant as approved & required by public agency

Sand - Gradation 0 - 30 (Quarry sand not)

NOTE: USE 14 AWG WIRING, (ref [section 1.6.8](#)) APPROVED BY LOCAL AGENCY FOR IN-ROADWAY WARNING SIGNAL ARRAY HOME RUN CONNECTION. FOR BOLLARD AND PUSH BUTTON'S, ALWAYS USE 8 CONDUCTOR 18 AWG MINIMUM DIRECT BURIAL CABLE TO ROUTE FROM ENCLOSURE TO OPPOSITE SIDE OF STREET FOR BOLLARD AND PUSH BUTTON'S.

3.5.3 TOP VIEW (SD-10C BASE PLATE SHOWN)

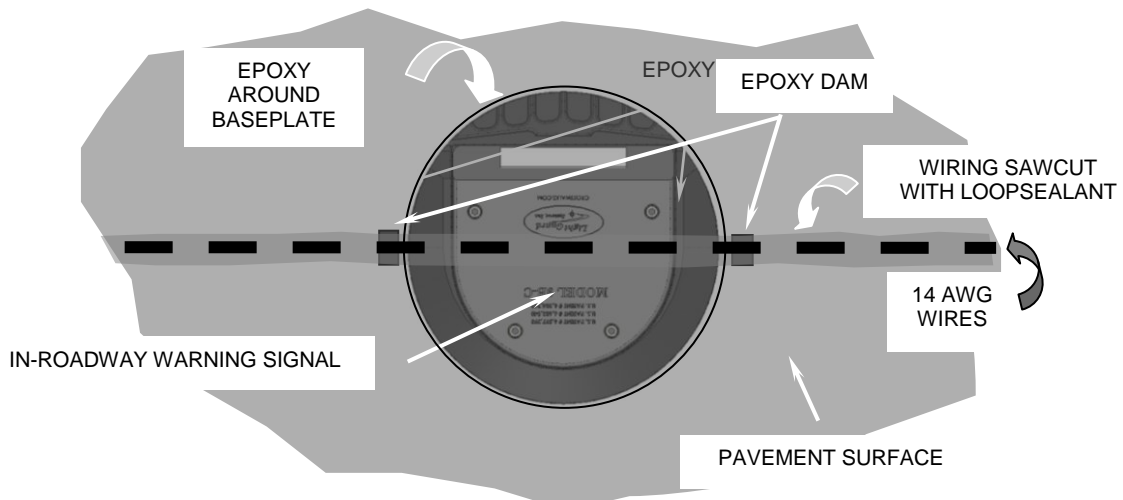

3.6 TYPICAL IRWL SIGNAL BASE PLATE WIRING DRAWING

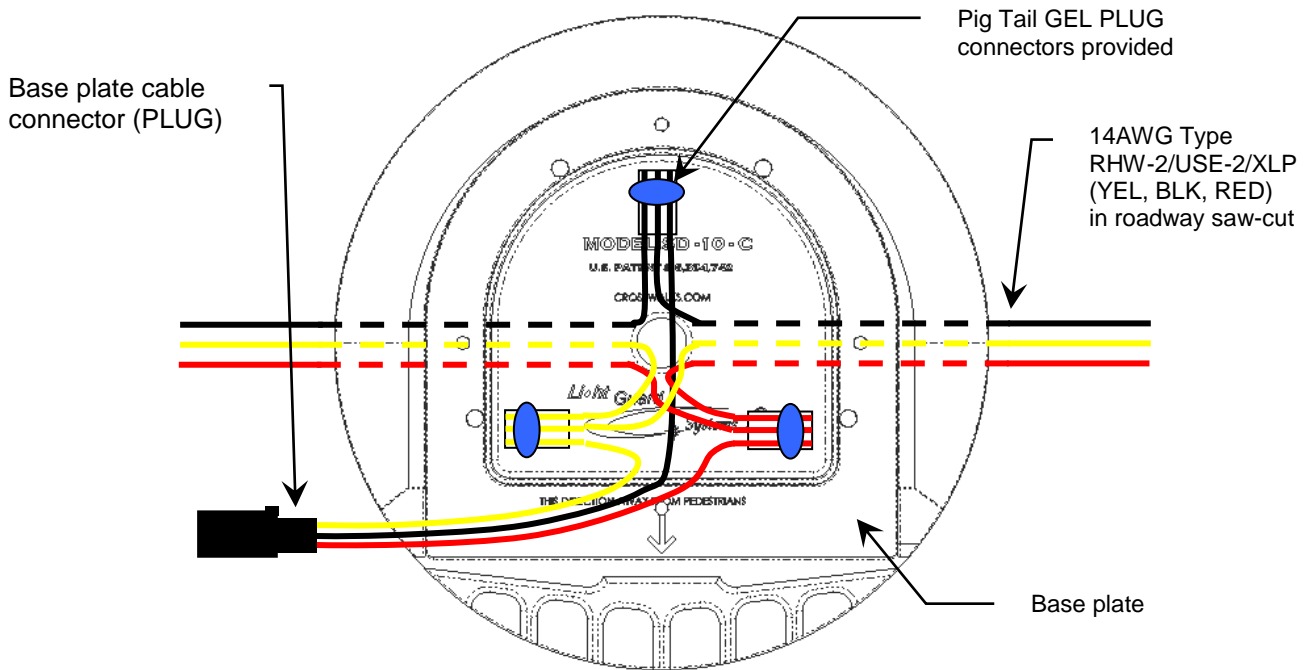

Figure 3.7A – Base Plate Wiring
(SD-10C shown)

3.6.1 GEL PLUG TERMINATION INSTRUCTIONS

The Scotchlok 314 Self-Stripping Electrical Pigtail Connectors are moisture resistant and can be used in place of the terminal blocks (in the signal head base plate) by performing the following steps.

Note: *This can only be done on heads that have enough wire extending from the roadway to allow the connector to set in the deepest part of the head when assembled. The connector requires 3/4" of wire to be inserted into it.*

- 1) Outer Diameter of type RHW-2/USE-2/XLP wire should be **MAX OD 0.17"**. This will allow the insulated wire to be inserted into the Scotchlok 314 connector. Any exposed bare wire should be clipped off from the wires when connected to ensure that no part of the conductor is exposed.

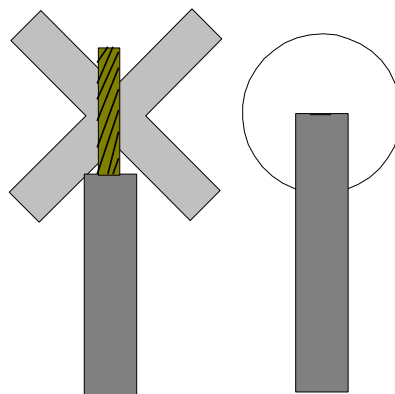

- 2) Insert all three wires to be connected into the three open holes in the connector, until they all reach the back end of the connector.

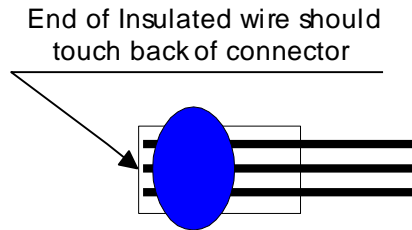

- 3) With a standard pair of slip joint pliers, pinch down on the blue cap of the connector until the outer edge of the blue cap is flush with the rim of the white connector housing. It may be necessary to wipe off the expelled gel after crimping.

Mechanics (slip joint) Pliers

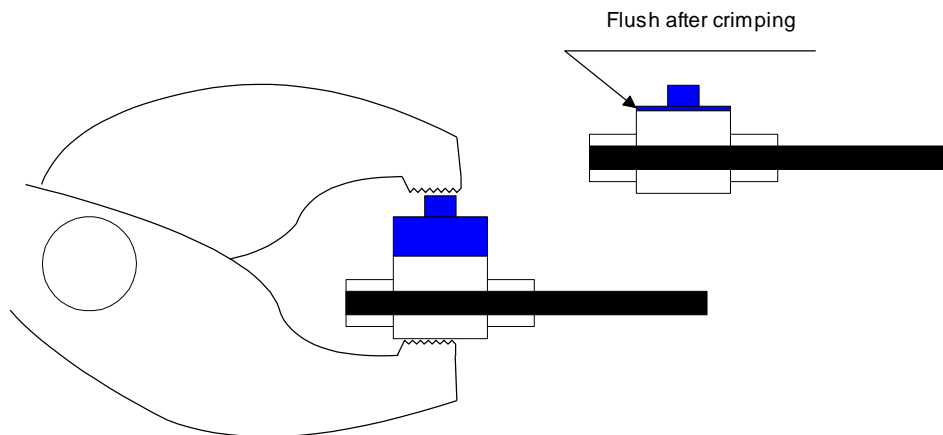
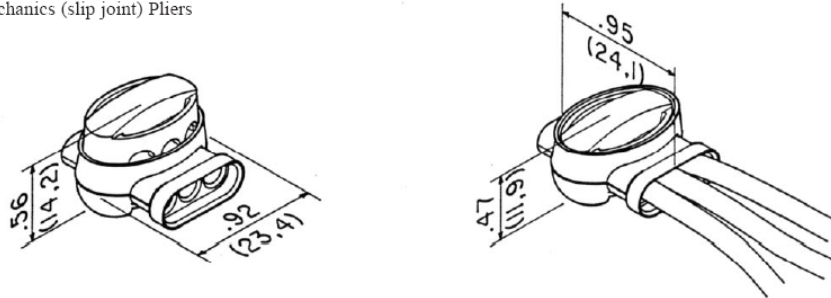

- 4) Place the connector in the bottom (lowest part) of the base cavity and route the wires so no pinches will occur when the head is tightened. Double-sided adhesive tape can be used to hold connector in place until head is re-installed.
- 5) Plug head into connector and fit head into base. **Adjust wires so NO PINCHES occur.**

3.6.2 SAMPLE LIGHTGUARD SYSTEM IRWL DIAGRAM

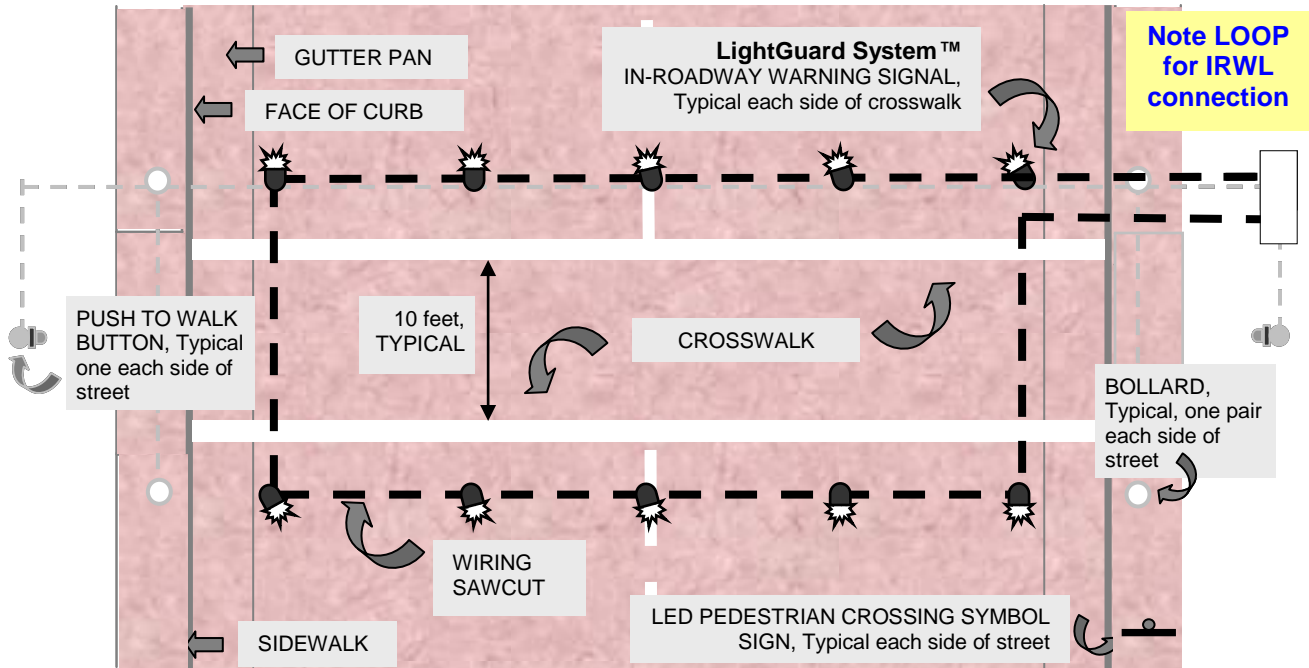

Refer to section [3.7.1](#) & [3.7.2](#) for IRWL Aiming and Alignment

3.7 CONVERGENCE ZONES

The “Zone of Convergence” refers to the area in the lanes of travel where the beams from the in-roadway LED lights merge. This “zone” gives the driver adequate time to react to the presence of a pedestrian by drawing his/her attention to the crosswalk. When aligning signal heads, great care must be taken to position them correctly to achieve this desired distance.

If the speed limit on the roadway is 25 mph, the “zone” should be approximately 250’ out from the signal heads. If the speed limit is 45 mph, signal heads should be aligned to make the zone 350’ to 400’ away from the signal heads. See chart for additional stopping distances based on road conditions and rate of speed.

Note: Alignment of in-roadway warning signals to be site specific - city engineer or roadway authority to establish “control points” for each actual location. Control points may vary depending upon terrain, slope, vehicle approach speed, or regulation etc.

Chart - Minimum Vehicle Stopping Distance on Dry Pavement

Posted Speed Limit	1 Second Reaction Time	Braking Distance	Total Stopping Distance
25 mph	37 feet	53 feet	90 feet
30 mph	44 feet	81 feet	125 feet
35 mph	51 feet	110 feet	161 feet
40 mph	59 feet	143 feet	202 feet
45 mph	66 feet	184 feet	250 feet
50 mph	73 feet	227 feet	300 feet
55 mph	81 feet	271 feet	352 feet
60 mph	88 feet	323 feet	411 feet

3.7.1 TYPICAL IRWL SIGNAL ALIGNMENT - STRAIGHT ROADWAY

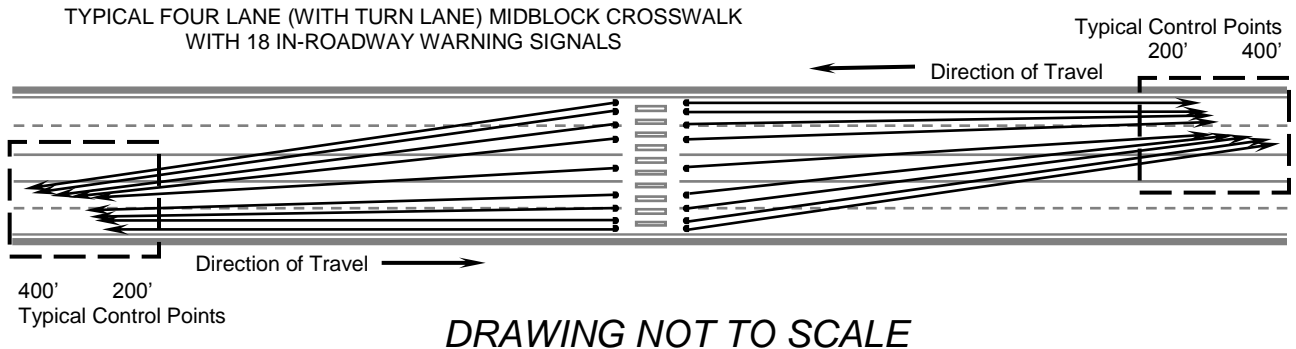

3.7.2 TYPICAL IRWL SIGNAL ALIGNMENT – CURVED ROADWAY

Determining the location of the “Zone of Convergence” on a curved roadway is similar to a straight roadway. Using the chart showing the *Minimum Stopping Distance on Dry Pavement*, determine the total stopping distance based upon the speed limit of the roadway. The **minimum** starting point of the convergence zone is determined by the **minimum** stopping distance on dry pavement for the posted speed limit. This minimum stopping distance includes a motorist decision distance, based on a one-second reaction time, plus the necessary speed deceleration distance required to come to a complete stop under optimum conditions.

As an example, the minimum stopping distance on dry pavement for a roadway with a 35 mph speed limit is approximately 161 feet. This 161 foot minimum distance would allow a motorist to visually recognize the flashing amber LED lights, slow down, and if necessary, bring his/her vehicle to a complete, safe stop.

Signal heads should be aligned to make the LED lights and therefore the zone appear as soon as possible as the driver approaches. On curved or winding roads, the entrance to the zone isn't always at the optimal distance to provide the earliest possible notification to approaching vehicles. Optional LED signal heads may also be installed down the center line of the road to give even more advance warning, giving the driver time to brake and stop for the pedestrian.

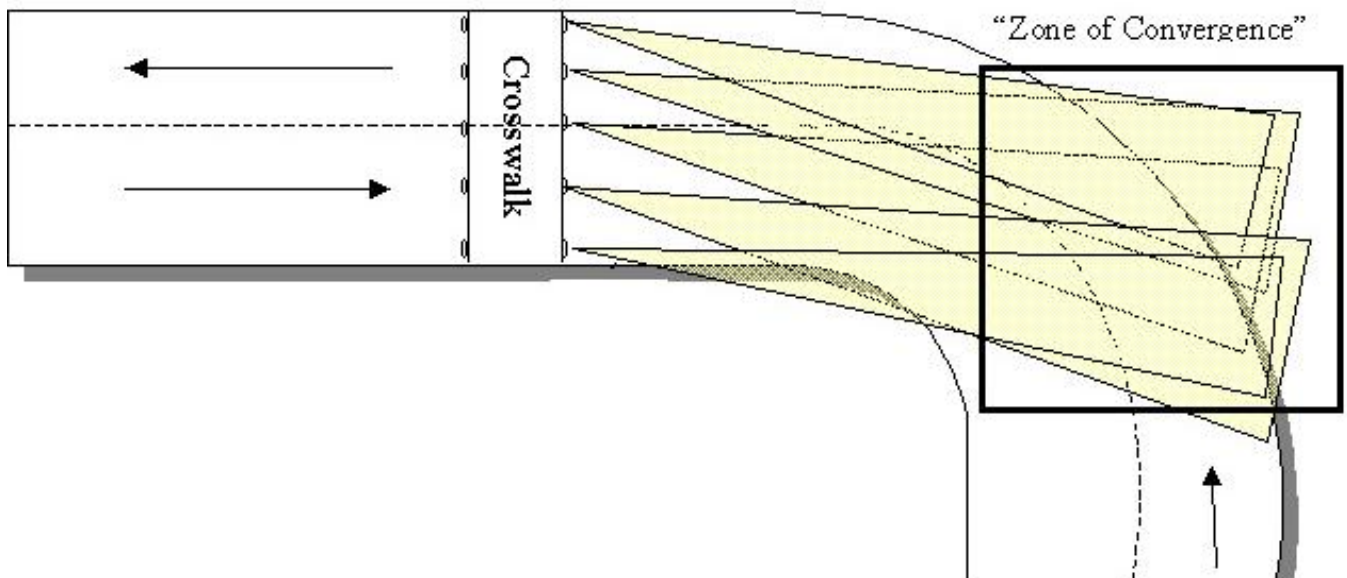

4 AUTOMATIC ACTIVATION SYSTEM - SMART CROSSWALK™

4.1 AUTOMATIC BOLLARD DETECTION SYSTEM DESCRIPTION

Automatic Activation System consists of “gateways” comprised of bollards or posts. Each bollard contains sensor circuitry, and they are placed so pedestrians entering a crosswalk must pass between them automatically activating the Smart Crosswalk™. The built-in sensors detect pedestrians using the crosswalk and detect their direction of travel. The built-in sensor module projects infrared beams of modulated light to the respective receiver module. Each module incorporates a high gain detector. This allows the System to activate for Crosswalk entry, and not for exit.

4.2 BOLLARD DRAWING

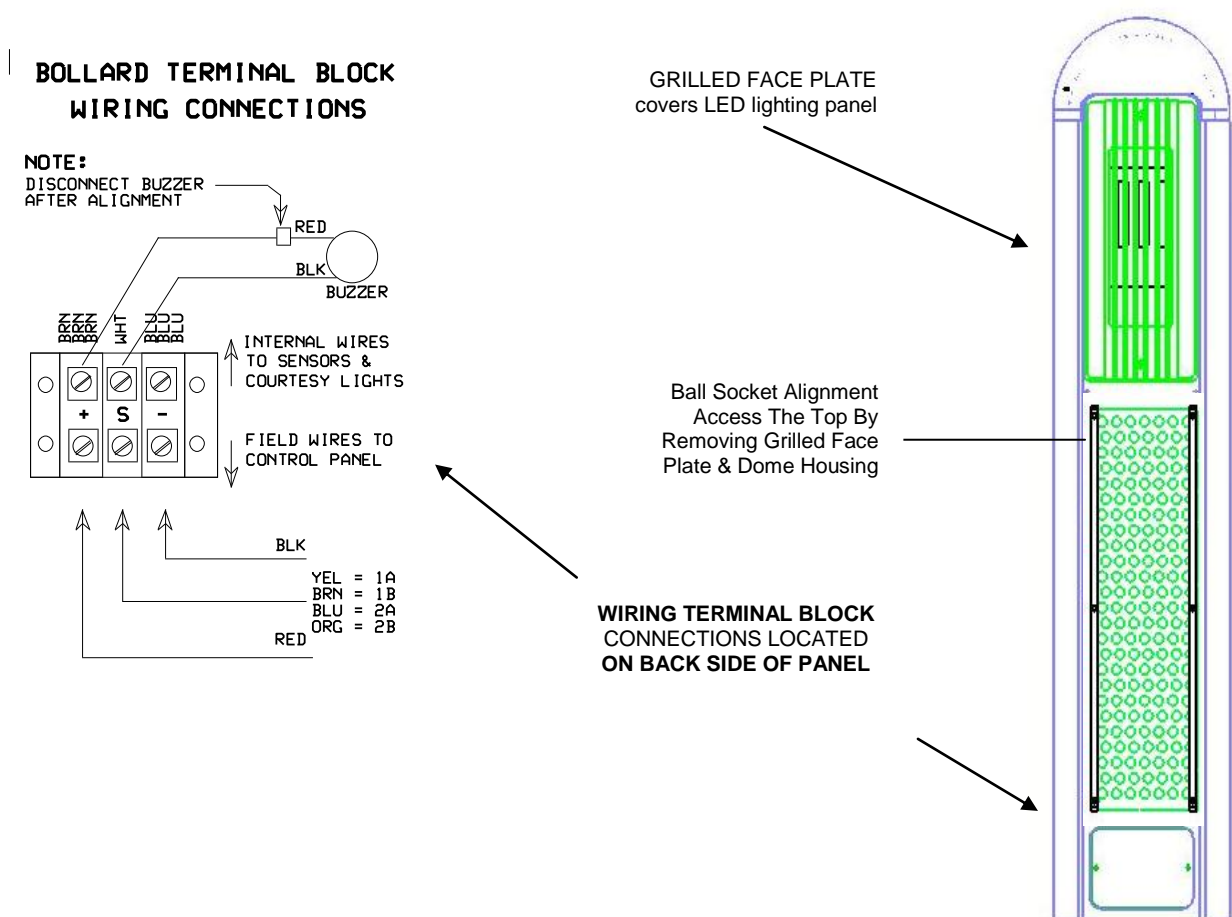

SPECIFICATIONS

SIZE:	Height: 42 inches Diameter: 8.5 inches
COLOR:	White (standard)
MATERIAL:	Extruded Aluminum Body with Cast Top
DETECTION METHOD:	Break Beam Modulated at 880 nm
RATING:	12.5 volts DC (not to exceed 15 V)
DISTANCE:	Not to Exceed 50 feet between Bollards
OPERATING TEMPERATURE:	-20° C to +70° C Humidity 90% at 50° C (non-condensing)

4.3. BOLLARD INSTALLATION GUIDELINES

4.3.1. INSTALLATION STEPS

- Step 1 Prior to installing bollards, the proposed site should be inspected several times to observe the everyday habits of local citizens who utilize the crosswalk. Particular attention should be paid to how far back pedestrians may “cut the corner” when entering the crosswalk. Bollards, as positioned, may not detect every pedestrian using the crosswalk. For example, a 12 foot wide crosswalk (dimension from outside crosswalk stripe to outside crosswalk stripe), bollards would be positioned approximately 5 to 6 feet outside of the outer edge of the crosswalk stripe and about 18 to 24 inches behind the face of curb. Once bollard locations have been determined, wiring, or conduit, may be run prior to installation of the hold down bolts (See Section [4.3.2](#)).
- Step 2 The preferred method of securing bollards into position is to remove an 8 inch square section of sidewalk then dig approximately 18 inches and set anchor bolts in 6 sack concrete mix (Refer to Bollard Mounting Detail Section [4.3.4](#)). Other methods are acceptable, such as drilled anchor bolts, however, the bolts may become loose as a result of the bollard being bumped. A loose bollard will cause the calibrated internal sensors to become misaligned (reference section [4.5.1](#) for alignment). J-Bolt alignment template is provided. Snap a “chalk line” between bollard pair locations to ensure that j-bolt templates are directly facing each other (not skewed).
- Step 3 After bollard anchor bolts have been set, and the concrete has cured, the bollards can be secured to the anchor bolts. Position the base of the bollard approximately .125 inch to .25 inch above the finished sidewalk grade, level, and secure. All hardware MUST be tightly secured. If installed on a sloping sidewalk, ensure that bollard is vertical using leveling nuts.
- Step 4 Run wires and make final wiring connections to each bollard (See Section [4.2](#)). Make wiring connections to terminal blocks in enclosure (See Section [4.3.2](#)). Once wiring connections have been completed the bollard light sensors are ready to be aligned (See Sections [4.5](#)).

4.3.2. SAMPLE BOLLARD LAYOUT AND WIRING DIAGRAM

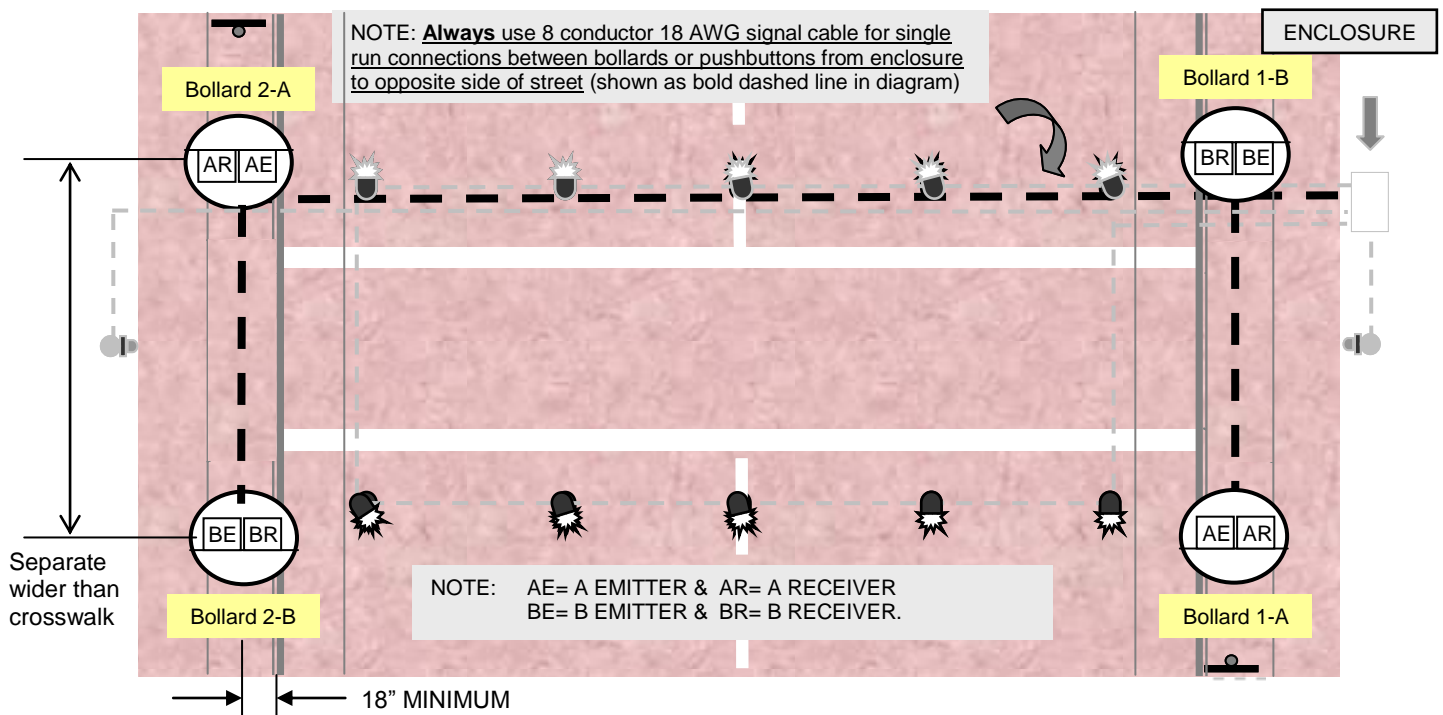

DRAWING NOT TO SCALE

Refer to section [3.7.1](#) & [3.7.2](#) for IRWL Aiming and Alignment

4.3.3 BOLLARD WIRING TERMINAL BLOCK CONNECTIONS

ENCLOSURE TERMINAL BLOCK CONNECTIONS FOR BOLLARDS:													
1	1	2	2	P	P	S	S	B	B	G	G	G	G
A	B	A	B	A	B	+	+	+	+	N	N	N	N
										D	D	D	D
Y	B	B	O						R	B			
E	R	L	R						E	L			
L	O	U	A						D	A			
L	W	E	N							C			
O	N		G							K			
W			E										

4.3.4 BOLLARD MOUNTING DIAGRAM

USE TEMPLATE PROVIDED TO INSTALL
 Ø .50 J - BOLT INTO NEW CONCRETE.
IMPORTANT: MAKE J - BOLT HEIGHT AS SHOWN.

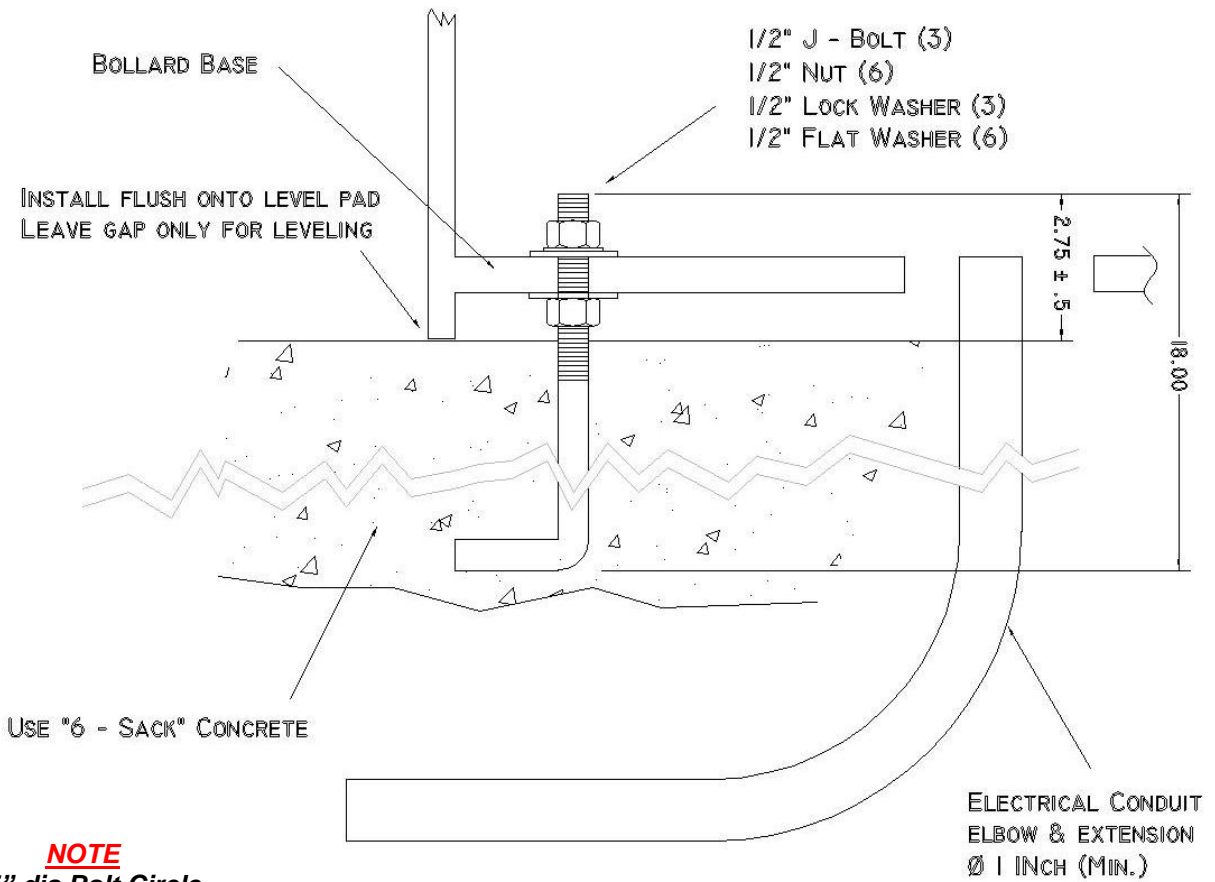

NOTE
 5.5" dia Bolt Circle
 Template(3 @ 120°)
 furnished by
 LightGuard Systems

NOTE: To alleviate wire access or electrical connection difficulties, conduit height should not exceed 1" above grade – unless required by local regulations

4.4 BOLLARD SENSOR ADJUSTMENT

Each bollard is equipped with detection sensors 1 transmitter/emitter and 1 receiver (See Section [4.3.1](#)). To adjust the detection sensors follow the procedure below;

- Step 1** Remove upper frosted glass grilled faceplate on bollard 1-A, located near enclosure (See Section [4.2](#) & Figure 4-5)
- Step 2** Remove 2 counter sunk Allen screws at the bottom of frosted glass opening.
- Step 3** Disconnect Brown & Blue terminal block wires from lighted window panel (courtesy light LED).
- Step 4** Slide rounded top of bollard (Light Dome Assy) upward and out.
- Step 5** Standing behind the bollard, look down 18” into the top portion of Bollard 1-A. There are 2 black colored sensor modules. The sensor on the right is the Zone receiver and the sensor on the left is the Zone emitter (See [section 4.3.1](#) & Figure 4-5).
- Step 6** With PCU enclosure door open, observe the 2 rows of Activation LED indicators immediately below, and slightly to the right of, the PCU keypad (See Section 2.5.1, pg. 8). Starting from left, to right, the first yellow upper LED is Zone 1A, and the green LED immediately below is Zone 1B, and the second yellow upper LED is Zone 2A, and the second green LED immediately below is Zone 2B. (Note: some older model PCUs may have all green LED indicators lights). When one of the Activation LED’s is illuminated, the power control unit (PCU) has been signaled that an object has entered the activation zone. Once zone sensor A is triggered, followed by zone sensor B, the system is activated for the desired cross time. If an Activation LED is illuminated but no object has entered the activation zone, then the receiver is not receiving the emitter’s beam (See note below, this page)
- Step 7** Repeat above procedure for bollards 1-B, 2-A, and 2-B. Note that standing behind each bollard, the emitter is always on left side and receiver is always on right side.

4.5. BOLLARD ALIGNMENT

After following steps in Section [4.4](#), if any activation LEDs in the PCU are illuminated, this indicates bollard detection sensors are out of alignment. To adjust alignment of the bollards refer to Section [4.5.1](#), and follow the procedure below:

- Step 1** - Determine that bollards 1A and 1B are plumb, and aimed directly at each other. If the bollards are not aimed directly at each other, then align sensors following steps in Section [4.4](#) above to compensate for bollard misalignment.
- Step 2** - Make sure bollard piezo-electric buzzer at bottom of bollard is temporarily connected with red wire to + and black to S. If the sensor is *not aligned* the buzzer will sound.
- Step 3** - Ensure there is power to emitting sensor in each bollard, (when standing in behind the bollard the emitter is on the left side). If there appears to be a power problem, correct then continue.
- Step 4** - Adjust a bollard’s receiver and emitter sensors by 1) loosening screws on each side of sensor and move sensor until piezo buzzer silences. When properly aligned, each Activation LED indicator in the PCU will *NOT* be lit and the piezo will *NOT* sound which means that both detection zones are clear and ready for operation. 2) Tighten sensor screws when properly aligned and disconnect piezo. If Buzzers are not disconnected after alignment, then each time the Bollard Beam is “broken” the buzzer will sound momentarily. The LightGuard System is supplied with a portable mirror (located in electrical

cabinet) that can be used to view the LED status Indicators located on the back side of each of the bollard sensors. (Refer to Figure 4-5). **Under normal operation; 1) the emitter/transmitter LED Status indication will be green, 2) the receiver LED Status Indication will be green only when partially aligned, both green and yellow when perfectly aligned, and yellow only when the light beam is broken** (not receiving signal from emitter). If an LED status Indication is Orange, the sensor is shorted and requires troubleshooting.

Follow above Steps 1 through 4 for bollards 2A and 2B. Once bollards 2A and 2B are aligned, and reassembled, ensure that all Activation LED indicators (2 rows of LED's immediately below the PCU keypad), are not lit (See Section 2.5). Reassemble the bollards by reversing Steps 1 through 7, of Section [4.3.1](#)

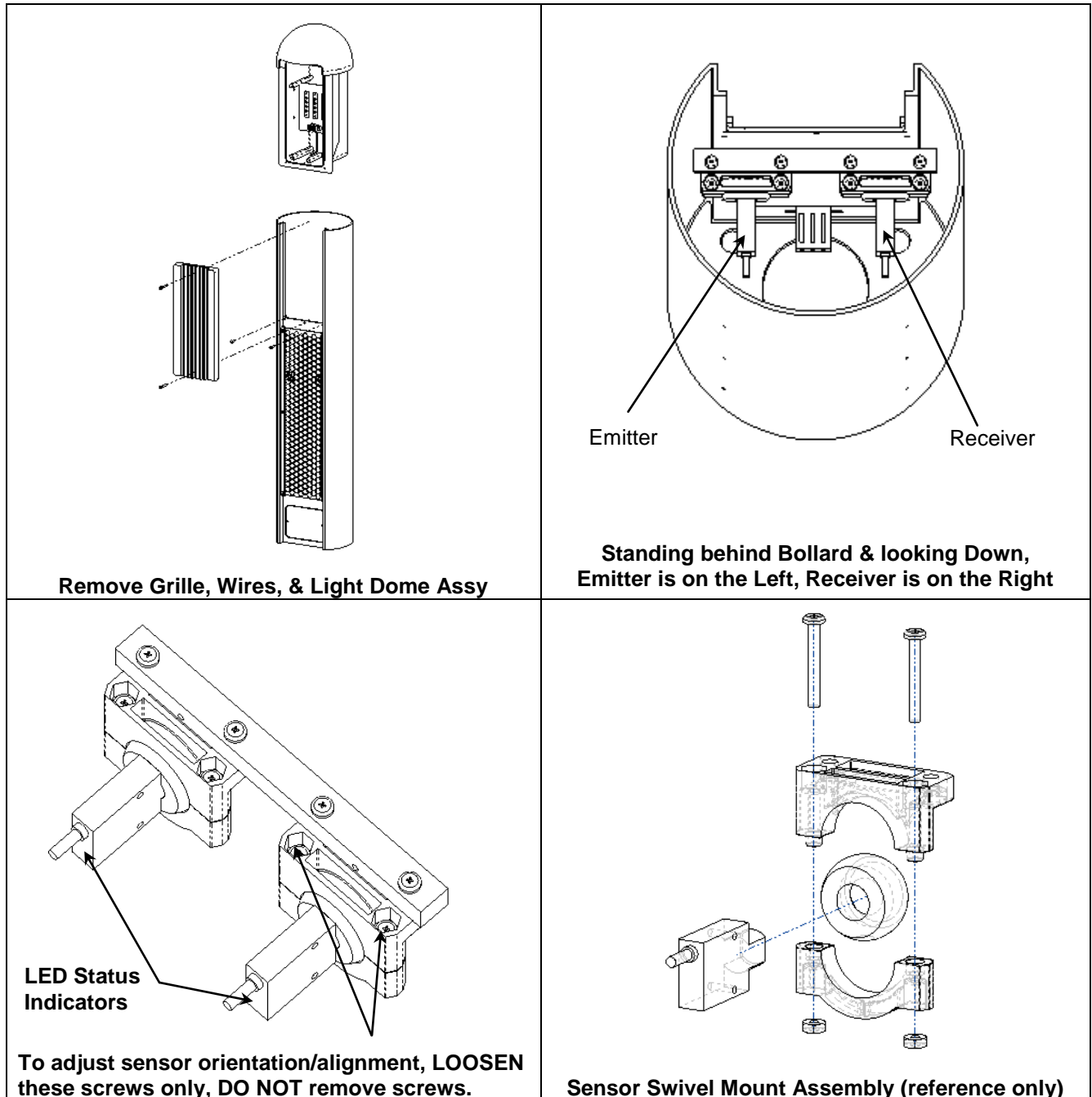
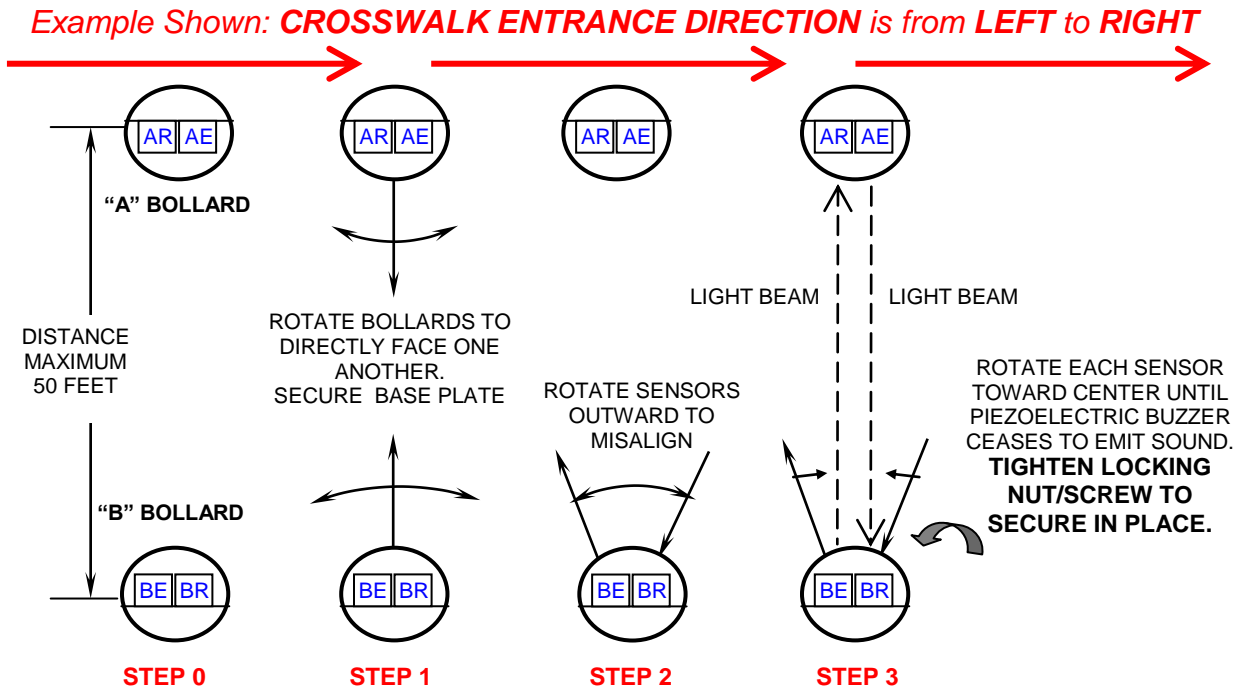

Figure 4-5

4.5.1 BOLLARD ALIGNMENT DRAWING



NOTES:

- ENTERING THE CROSSWALK, “A” BOLLARD IS ALWAYS ON THE LEFT, “B” BOLLARD IS ALWAYS ON THE RIGHT
- WHEN BOLLARDS ARE INSTALLED AT COPLANAR ELEVATION, THEN VERTICAL ALIGNMENT IS INHERENT.
- ELEVATION MISALIGNMENT SHOULD BE MINIMIZED
- THE SET UP DEPICTED IS AN **EXAMPLE OF BOLLARD PAIR ENTERING CROSSWALK FROM THE LEFT**
- AE= EMITTER INSIDE THE “A” BOLLARD – LOCATED ON *LEFT SIDE* AS THE CROSSWALK IS ENTERED
- AR= RECEIVER INSIDE “A” BOLLARD – LOCATED ON *LEFT SIDE* AS THE CROSSWALK IS ENTERED
- BE= EMITTER INSIDE “B” BOLLARD – LOCATED ON *RIGHT SIDE* AS THE CROSSWALK IS ENTERED
- BR= RECEIVER INSIDE “B” BOLLARD – LOCATED ON *RIGHT SIDE* AS THE CROSSWALK IS ENTERED

4.6. BOLLARD DETECTION ZONE OPERATION

- Step 1** Ensure zones are correctly connected to the flashing controller by observing the Activation LED indicators immediately below the PCU keypad (see Section [2.8.1](#)) or alternatively on the left side on the ECP.
- Step 2** Observe pedestrian entering the crosswalk between the bollards. The first LED that lights should be yellow (PCU upper row is A zone), the second should be green (PCU lower row is B-zone - *lower rows are green in some PCUs*). If the LED’s illuminate in the reverse order, then the wires are reversed. To correct, reverse wires 1A and 1B at the PCU terminal block connections.
- Step 3** Observe pedestrian exiting the crosswalk. The activation LED indicators should light in order of Zone 2B, then Zone 2A. In this condition, the PCU will ignore the call signal and not initiate the flashing sequence.
- Step 4** Observe pedestrian returning from other side of street entering the crosswalk between bollards 2A and 2B. Ensure that when pedestrian enters the crosswalk between bollards that the 2A Activation LED (yellow) comes on, then the 2B Activation LED (green) comes on.

4.7 UNI-BOLLARD / ISAD INSTALLATION OPTION

The Uni-Bollard is similar to the standard Bollard. Both contain a courtesy light. The difference between the standard Bollard and the Uni-Bollard is that the Uni-Bollard contains 2 receivers instead of a receiver/transmitter pair. The Uni-Bollard is designed to be installed with an ISAD (which contains at least 1 broad beam width transmitter). Each Uni-Bollard is required to have 4 conductors – (1) 12VDC, (2) Switch wires, & (1) ground. The switch wires are terminated in the control panel in the manner described in section [4.3.2](#).

Access to the Uni-Bollard sensors is identical to the procedure noted in section [4.2](#). Electrical connections are made to clearly marked terminal posts located inside the Uni-Bollard.

The ISAD installs in the pavement in the identical manner as an In-Roadway Warning Signal shown in section [3](#). The recommended maximum distance between the Uni-Bollard & the ISAD for reliable operation is **25 feet**.

4.7.1 UNI-BOLLARD CONFIGURATION DIAGRAM

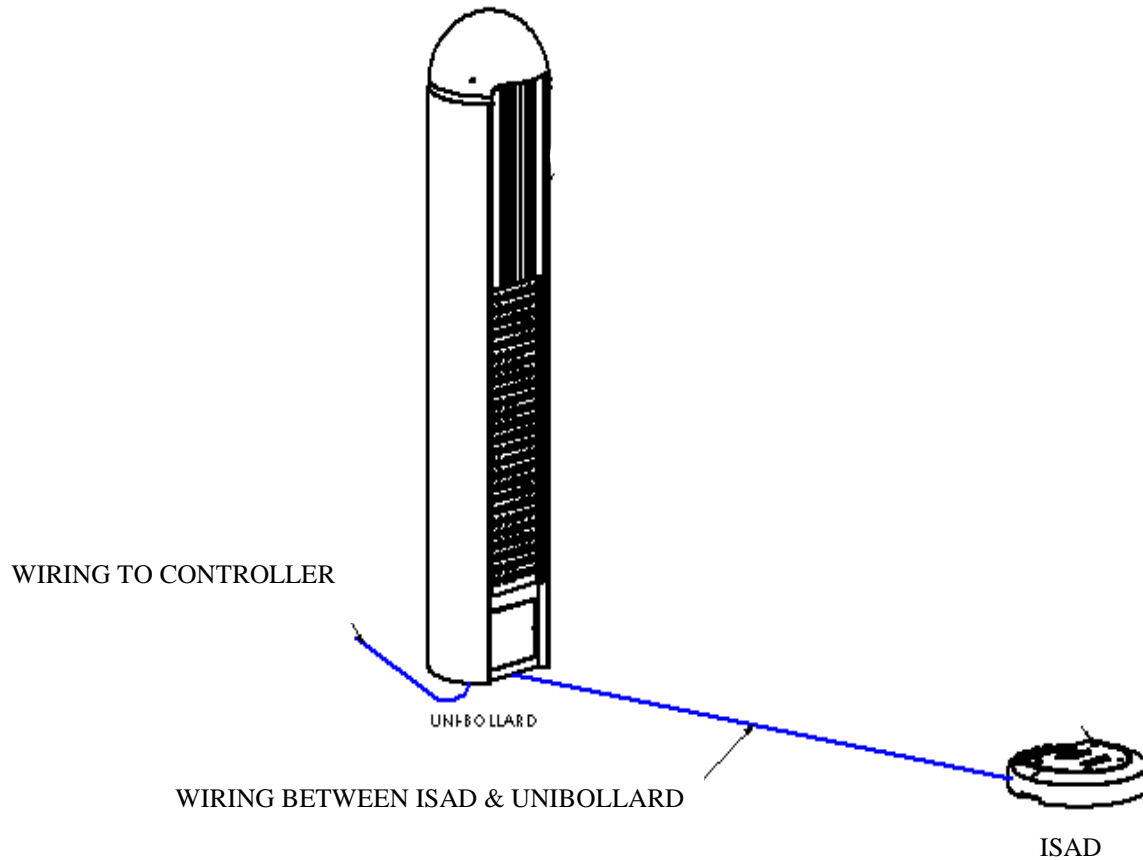

4.7.2 EXAMPLE UNI-BOLLARD INSTALLATION DIAGRAM

Typical Uni-Bollard installations are arranged with an ISAD installed in the roadway & a Uni-Bollard installed on the sidewalk. The drawing below depicts example locations for field installation.

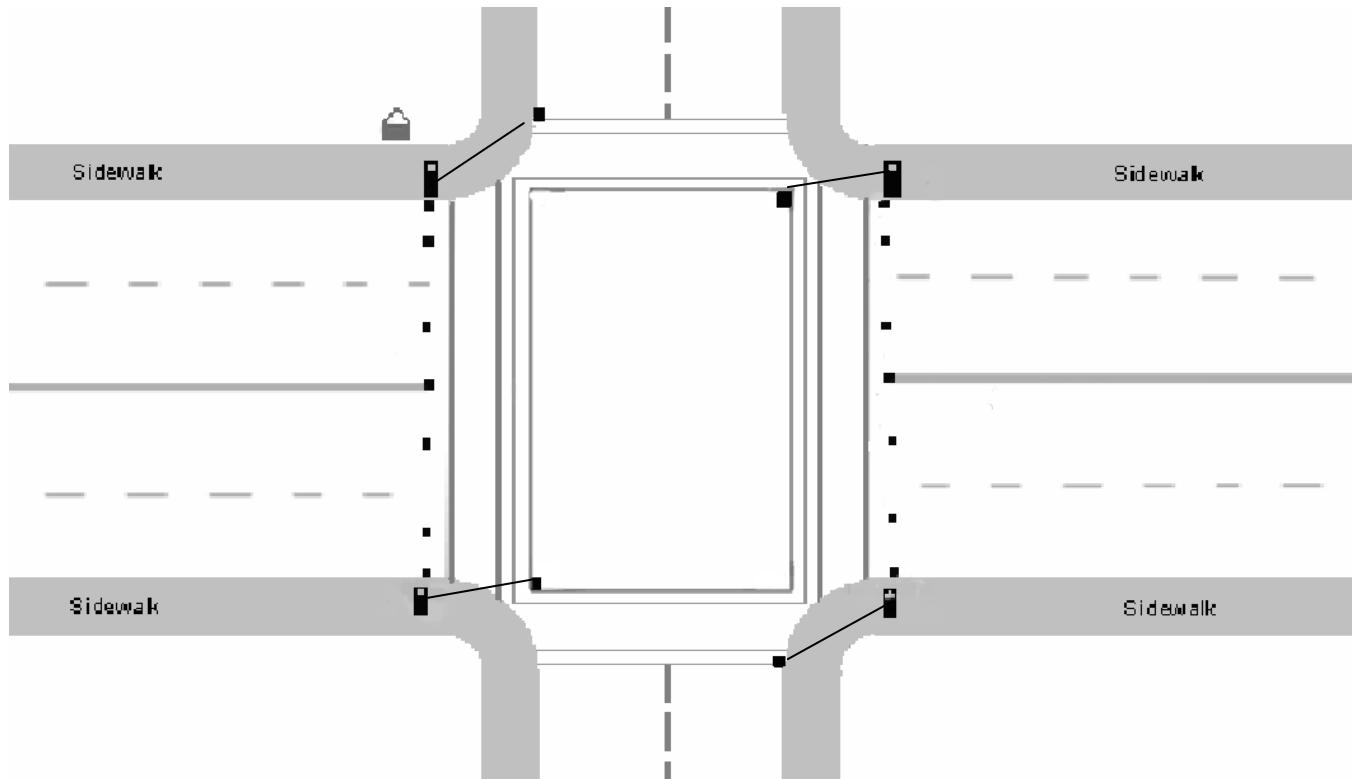

4.7.3 ISAD PLACEMENT CONSIDERATIONS

- The ISAD should not be placed such that Direct Sunlight is focused into the face of the ISAD. This could degrade activation reliability
- The ISAD should not be placed in the roadway such that debris or Water can “build up” on the face. This will cause excessive field maintenance.
- The ISAD should be placed relatively close to the curb (not in the flow of traffic). If the ISAD is placed in the flow of traffic, this will induce nuisance (false) activations of the crosswalk warning system.
- The ISAD should be oriented such that it is facing the Uni-Bollard & is relatively level with the roadway, however the ISAD may require tilting to ensure that the transmitters in the ISAD are pointed at the Uni-bollard. The Uni-Bollard sensors are used to effect the ISAD alignment.

4.7.4 UNI-BOLLARD WIRING DIAGRAM

The following diagram illustrates how to connect a Uni-Bollard & ISAD to the LGS controller cabinet. The ISAD is powered from the B+ and GND terminals. The crosswalk entrance side of the Uni-Bollard is connected to either 1A or 2A. The crosswalk exit side of the Uni-Bollard is connected to either 1B or 2B.

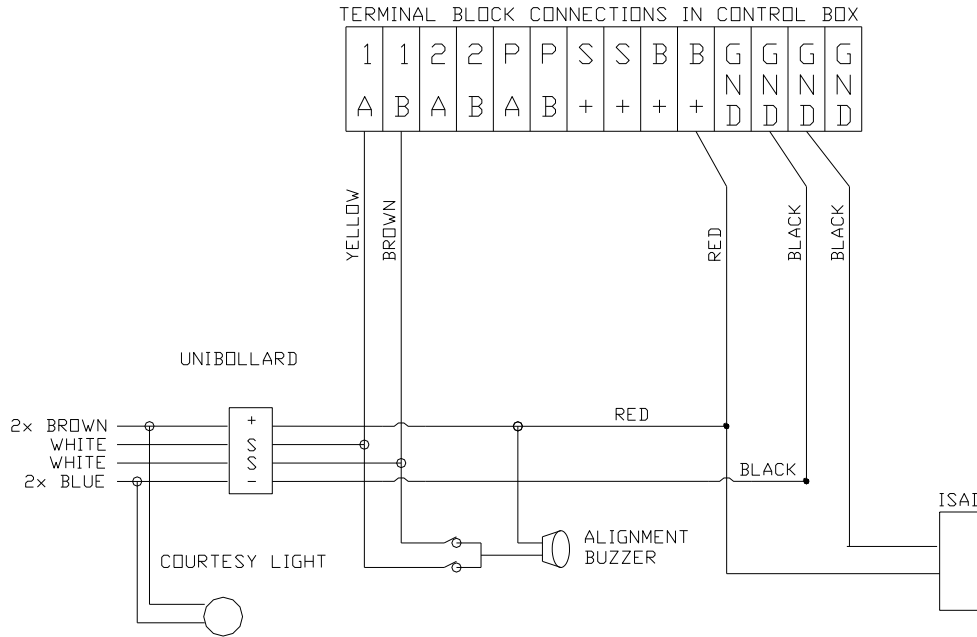

4.7.5 UNI-BOLLARD SENSOR ADJUSTMENT

The ISAD cannot be adjusted in the field. Only the Uni-Bollard can be aligned to the ISAD after installation. The Uni-Bollard sensors are adjusted as described in section 4.4. The audible buzzer in the Uni-Bollard is attached to one sensor for alignment & then subsequently disconnected. The audible buzzer is then attached to the other sensor for alignment & then subsequently disconnected.

5 PUSH BUTTON ACTIVATION

5.1 MANUAL PUSH BUTTON ACTIVATION DESCRIPTION

Manual installations utilize a standard pedestrian operated push button assembly to activate the system. In these installations, a pole mounted control box containing the push button, a small sign with the words “**CROSS WITH CAUTION**”, and a row of 4 flashing amber LEDs, as shown below, is placed near the entrance to crosswalk (refer to section 3.6.2). The row of 4 flashing, amber, LEDs indicates to the pedestrian the warning system is activated. The words “**CROSS WITH CAUTION**” remind the pedestrian to maintain vigilance for their own safety by paying attention to traffic conditions while crossing the street. This standard pedestrian activation push button device should be installed as recommended in the Manual on Uniform Traffic Control Devices (MUTCD) or other local agency approved specifications.

5.2 ILLUMINATED PUSH BUTTON ASSEMBLY

GENERAL SPECIFICATIONS

ASSEMBLY SIZE:	Height: 11.75 inches - Width: 5 inches
COLOR:	Green housing, yellow/black faceplate, silver tone 2 inch push button
FACEPLATE LIGHTS:	Amber Light Emitting Diodes (LEDs) which flash with system activation
MATERIAL:	Cast Aluminum
VOLTAGE:	12.5 volts DC (not to exceed 15 V)
MOUNTING:	See local agency approved standard specifications for location and height

5.3 SAMPLE PUSH BUTTON LAYOUT AND WIRING DIAGRAM

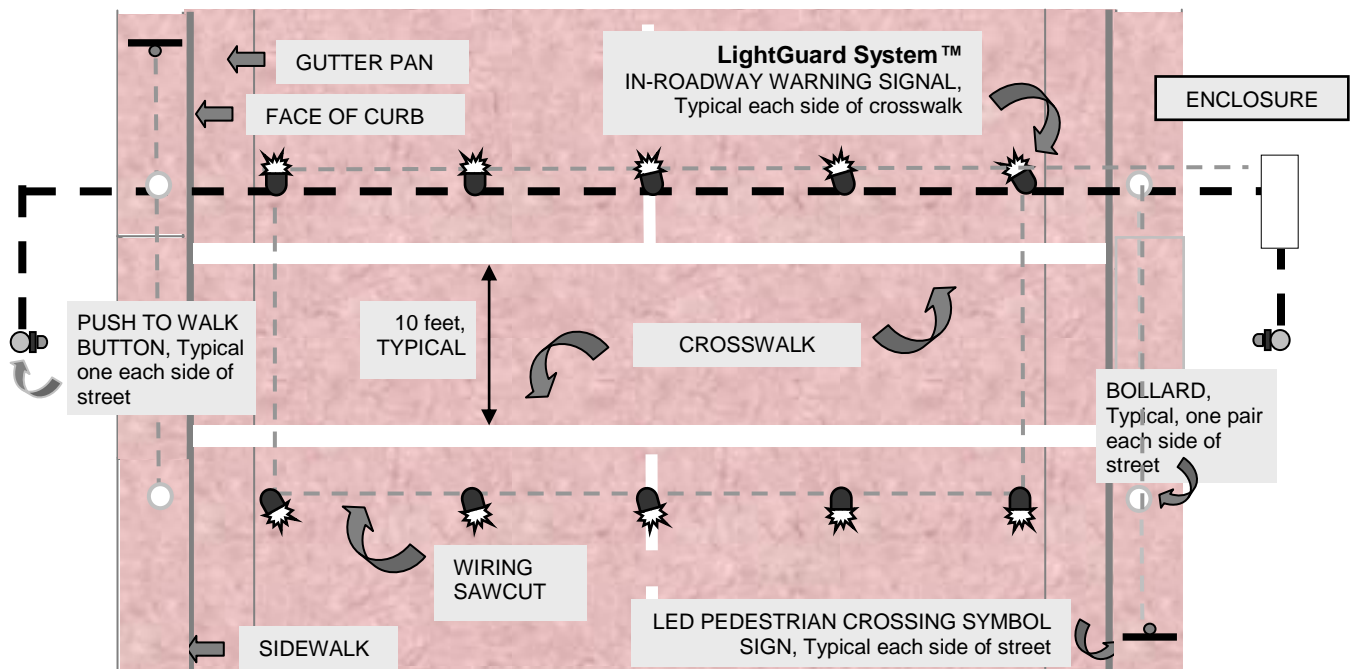

6 LED “ENHANCED” ILLUMINATED WARNING SIGNS

6.1 LED “ENHANCED” SIGN GENERAL DESCRIPTION

LightGuard System® installations may, as an option, utilize fluorescent-yellow-green (FYG) color, diamond shaped pedestrian crossing symbol signs (W54, W11A-2, W-11-2, W-54-A or equivalent), equipped with flashing amber LED modules located below the walking pedestrian symbol (See below). These signs are placed at, or before, the crosswalk to assist in warning approaching motorists that a pedestrian is in, or about to enter the crosswalk. The embedded LED modules flash at the LightGuard System® enhanced flash rate. This LED “enhanced” pedestrian crossing symbol sign should be installed at the crosswalk location as recommended in the Manual on Uniform Traffic Control Devices (MUTCD) to replace the standard yellow W54 sign. For school crossings, a W66 or W-63 type (S2-1 or S-2-1 in FYG) school symbol sign also available. NOTE: Any advance warning signs should be consistent with color of other signs.

6.2 LED “ENHANCED” PEDESTRIAN CROSSING SIGN DRAWING

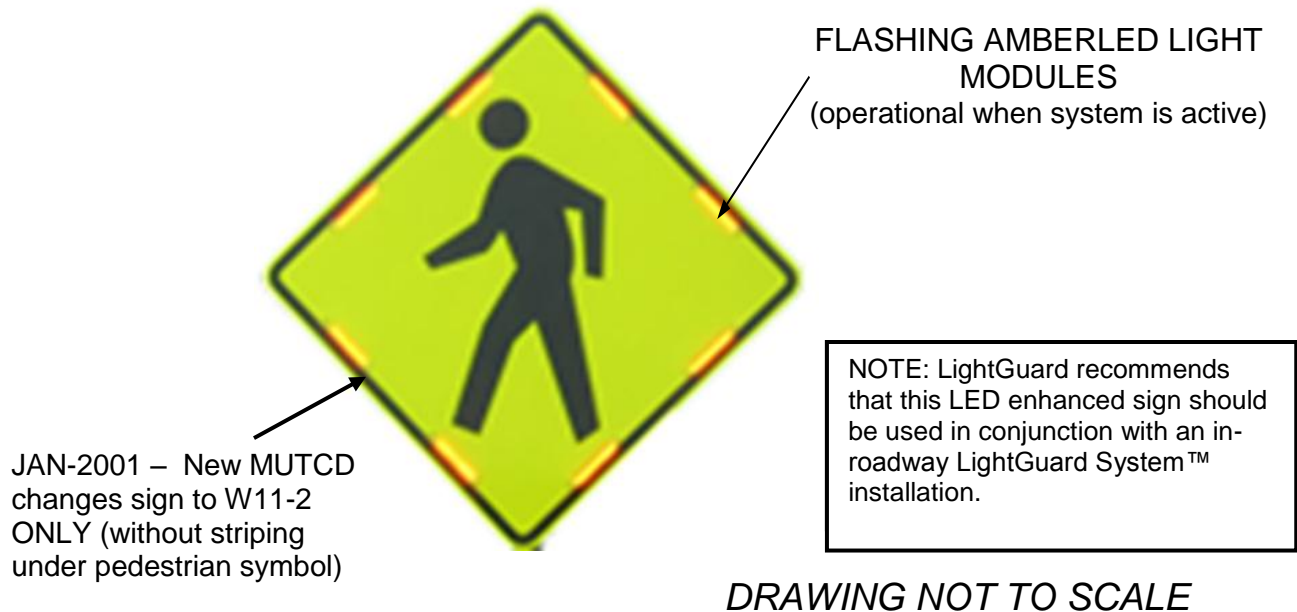

ACTIVE PEDESTRIAN CROSSING SYMBOL SIGN WITH LED MODULES

SPECIFICATIONS

SIZE:	30 inch x 30 inch
TYPE:	Standard configurations: W-54, W-54A, W-63, W-66, W-79, R-1, W-47, W-11A-2, W11-2, S-1-1, S-2-1, W-11-1, W-11A-1, R-1-1, W-10-1 Custom configurations available upon request
COLOR:	Standard fluorescent -yellow-green. Optional high intensity yellow
FACEPLATE LIGHTS:	Amber Light Emitting Diodes (LEDs) which flash with system activation
VOLTAGE:	12.5 volts DC (not to exceed 15 V)
MOUNTING:	Bracket assembly provided (tamper resistant fasten hardware to be supplied by installer) See local agency approved standard specifications for location and height

7 LIGHTGUARD SYSTEMS SOLAR POWER OPTION

7.1 INSTALLATION STEPS

1. Using the drawing, assemble the Solar Panel mount with the hardware supplied.
2. Use the 1/4" hardware to attach the module to the Module Rails.
3. Use the 5/16" hardware to bolt the Module Rails to the SPM-1 Pole Bracket.
4. Adjust the mount to the proper tilt angle for your site latitude.
5. Face the solar module due South (NOT MAGNETIC SOUTH) for Northern Latitudes and due North for Southern Latitudes.
6. ENSURE that the Batteries are fully charged prior to installation.

7.2 SOLAR MODULE

Use the 14 / 2 TC tray cable supplied to wire the solar module into the charge control panel inside the enclosure. It is recommended that 1/2 inch flexible metal conduit be run between the solar module junction box and the mast to protect the tray cable. An opening in the mast to accept the conduit will need to be provided.

Remove the cover of the black junction box on the back of the module and note the 6 screws. Also, note a positive (+) sign and a negative (-) sign which show the 2 positive and negative terminals. Connect 1 wire to either of the 2 positive (+) and negative (-) terminals. Use the red conductor for positive and the black for negative. Do not use either of the 2 screws in the middle, these screws are not electrically connected to the module circuit.

Route the tray cable down the mast into the enclosure. Make sure the solar module is covered, or not connected to the tray cable, when routing the cable through the enclosure. Even in low sunlight the module can produce 18 to 20 volts.

7.2.1 SOLAR MODULE DESCRIPTION

The solar array consists of a minimum 75 watt solar power module which is to be pole mounted. This solar module is designed to charge the two 12 volt batteries in the system. In full sun, this module can produce a maximum on 4.25 amps when charging the battery. During the day, the amount of charging current will vary with the intensity of the sunlight hitting the module. The open circuit voltage (voltage when not connected to charging circuit) can be up to 21 volts.

7.2.2 SOLAR MODULE MOUNTING

The solar module is to be mounted to the side of a 4" galvanized mast using the aluminum side-of-pole mount and hardware supplied. **The solar module must be oriented facing TRUE South.** Attach the mounting rails to the pole bracket and adjust the tilt angle to create an angle setting for your local latitude from horizontal facing South. Refer to sections [7.2.3](#) & [7.2.4](#) for orientation details. Use U-bolts to secure the mount to the mast

Instructions for SOLAR PANEL MOUNT, model #HPMH-50/90, side-of-pole mounting kit:

PARTS LIST	
Part	Qty
SPM-1	1
Module Rail	2
1/4-20X3/4" SS Bolt	4
1/4-20 SS Flat Washer	4
1/4-20 SS Lock Washer	4
1/4-20 SS Nut	4
5/16-18 x 1" SS Bolt	4
5/16-18 SS Flat Washer	8
5/16-18 SS Lock Washer	4
5/16-18 SS Nut	4
4" Hose Clamp	2
4" U-Bolt	1

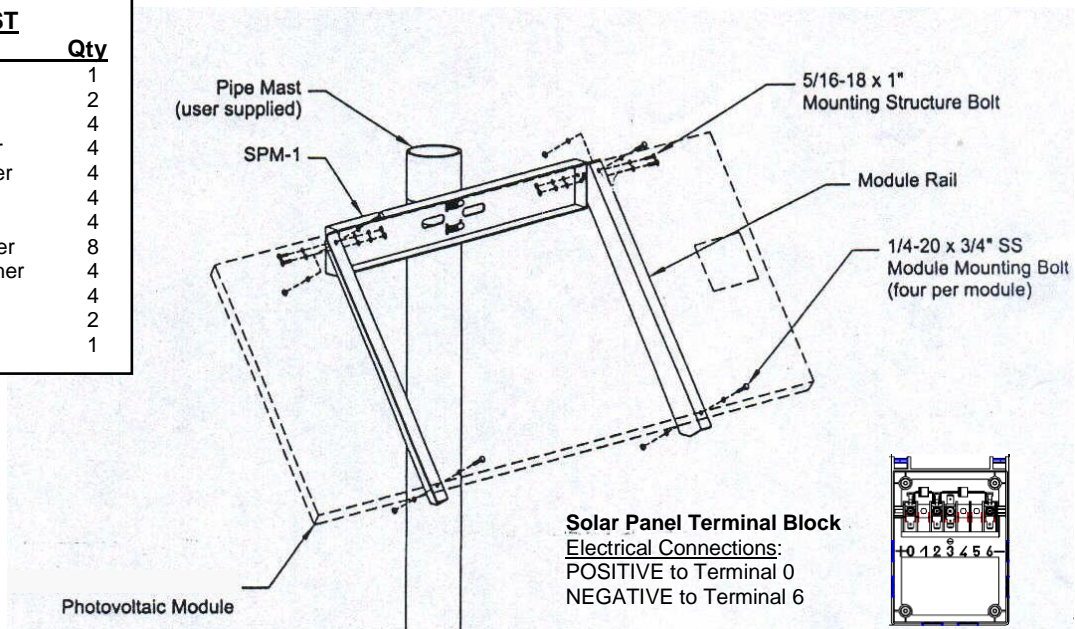

7.2.3 ORIENTING THE SOLAR MODULE

The following information was authored by www.powerupco.com & is reprinted herein without permission

It is important for proper system operation that the array be oriented true South (if you are located in the northern hemisphere). The directions of magnetic South and true South differ from one another depending on geographic location. This variance is called declination. Check the deviation for your region in order to extrapolate true South from a compass heading of magnetic South. The map in this section shows the magnetic declination for the US. For example, central Oklahoma falls between the 8° E and the 10° E lines. This means that the north point of a compass points about 9° E of true north. So true north is actually 9° to the WEST of where the compass points

7.2.4 DECLINATION ANGLE FOR SOLAR PANELS

The following information was authored by <http://www.oksolar.com/> and is reprinted herein without permission

When installing photovoltaic modules, be aware that they generate maximum power when facing the sun directly. The fixed position which approximates this ideal over the course of the year, thus maximizing annual energy production, is facing due South (in the Northern Hemisphere) or due North (in the Southern Hemisphere) at the angle listed in the table in the next column. Note that these orientations are **true**. The table below shows the fixed angle above horizontal at which modules should be installed in order to maximize annual energy output.

At some installations, it may be cost-effective to adjust the tilt seasonally. At most latitudes, performance can be improved during the summer by using an angle flatter than the chart's recommendation; conversely, a steeper angle can improve winter performance.

If modules are not cleaned regularly, it is recommended that they not be mounted at an angle flatter than 15°. Flatter angles cannot take full advantage of the cleansing action of rainfall.

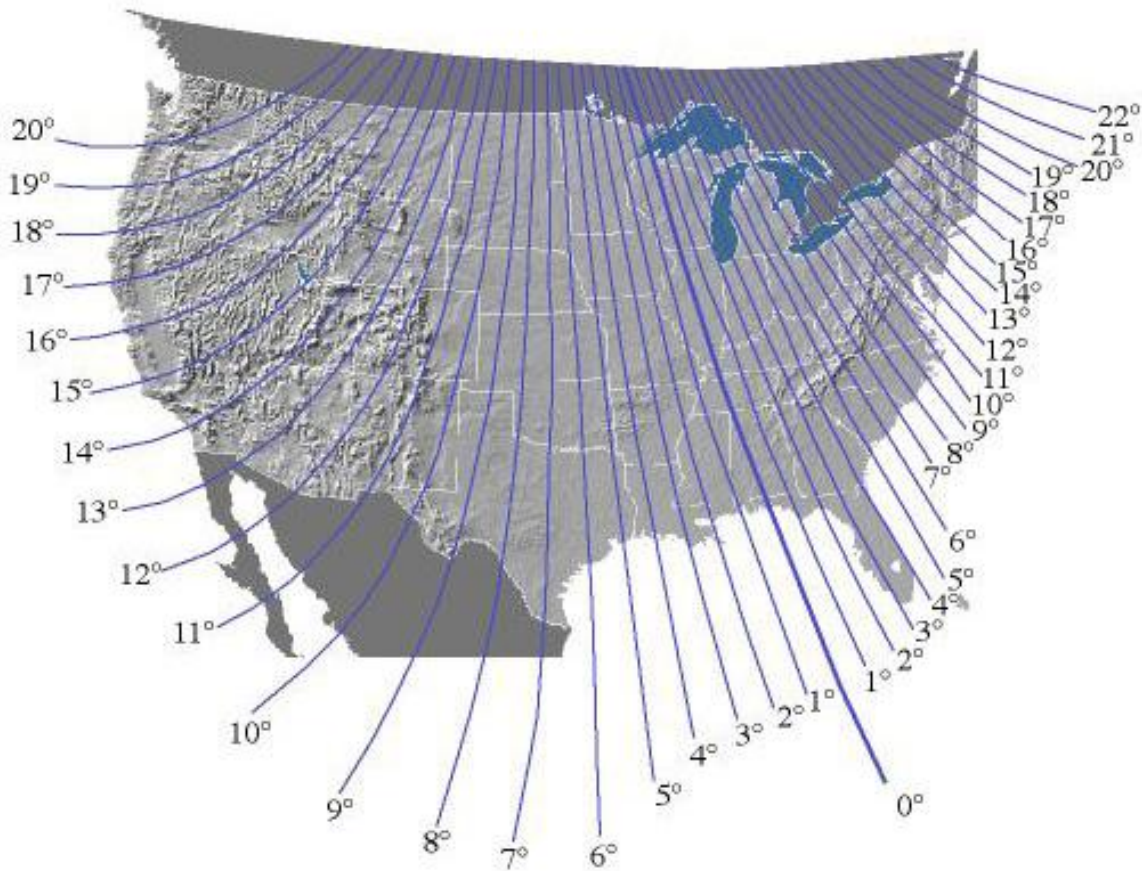

7.2.5 MODULE TILT ANGLE

Solar modules produce the most power when they are pointed directly at the sun. For installations where the solar modules are mounted to a permanent structure, the solar modules should be tilted for optimum winter performance. As a rule, if the system power production is adequate in the winter, it will be satisfactory during the rest of the year. The module tilt angle is measured between the solar modules and the ground.

Example: A module mounted in Miami, Florida (latitude 26° should be tilted at approximately 31° from horizontal, and should be faced due South.

Latitude Site	Tilt Angle
0-15°	15°
15-25°	SAME AS Latitude
25-30°	add 5° to local latitude
30-35°	add 10° to local latitude
35-40°	add 15° to local latitude
40° +	add 20° to local latitude

7.3 SOLAR SYSTEM BATTERIES

The enclosure contains 2 SLA batteries, the PCU (power control unit) and the charge controller. Two 12 volt deep cycle sealed gel-cell batteries are supplied. Each battery is rated at approximately 100 amp hours. The batteries are to be wired in parallel (positive-to-positive and negative-to-negative) to give 12 volts nominal at 200 amp hours of storage. Use the red and black battery cables supplied to parallel the batteries. Install the wiring into the terminal blocks & circuit breaker before installing the batteries.

Use the red and black cables, supplied with the ring terminals, to make the battery connections. Connect the red cable to the positive post on 1 battery and the black cable to the negative post on the other battery. This will ensure even charging between the 2 batteries (note figure below).

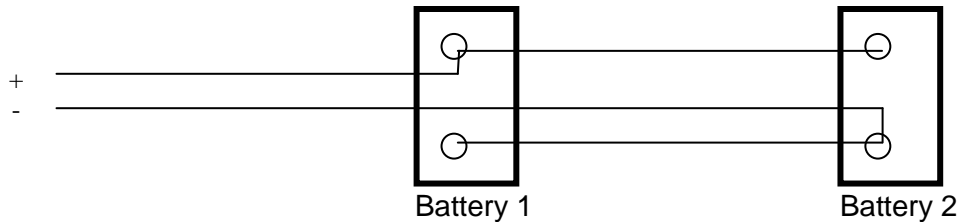

Connect the red and black #14 tray cable wires, from the solar module, to the labeled circuit breaker and negative buss block (refer to Section [2.4.3](#)).

7.4 CHARGE CONTROLLER

7.4.1 CHARGE CONTROLLER WIRING

The charge controller, located inside the enclosure, provides all wiring connections for the solar module, batteries, and power to the PCU. The PCU controls power to the in-roadway warning signals, signs, and push buttons.

Ensure all circuit breakers are OFF before making any connections. There are three 15 amp circuit breakers:

- 1) Solar Module circuit breaker; controls power from the solar module.
- 2) Load circuit breaker; controls load power to the PCU, in-roadway warning signals, and signs.
- 3) Battery Main circuit breaker; controls battery power to the system.

7.4.2 SOLAR CONTROLLER

A charge / load controller is located on the charge control panel (for further information / specs, contact your LGS representative). This controller is being used to regulate the battery charging and protect the batteries from being over discharged. The charge controller is pre-wired and factory adjusted. Do not make any adjustments to the charge controller without contacting LightGuard Systems, Inc. first. Indicator(s) on the face of the controller indicates the battery state of charge. Note the legend on the face of the charge controller.

During normal operation, the charge controller will allow the battery voltage to rise up the approximately 14.1 volts while charging. This end-of-charge voltage will vary with temperature. The charge controller might employ a supplemental temperature probe attached to the side of one of the batteries in the enclosure. If supplied, attach the probe approximately three quarters of the way up the side of the battery case using the adhesive pad on the probe. This will ensure proper charging of the batteries throughout the year.

At night, the battery voltage should register between 12.0 and 12.8 volts depending upon how well the batteries were charge during the day. In times of exceptionally bad weather, and / or exceptionally heavy crosswalk usage, the battery voltage may drop below 12.0 volts. When the voltage drops to below approximately 11.8 volts, the charge controller will shut off power to the PCU and in-roadway warning signals ensuring protection of the batteries from damage as a result of over discharge. The charge controller will not allow power back to the PCU until the voltage rises back up to approximately 12.8 volts after several hours of charging. This solar power system is designed to operate in all weather conditions throughout the year.

A copy of the Charge Controller Owners Manual is available upon request.

8 TROUBLE SHOOTING / MAINTENANCE / AFTER INSTALLATION

8.1 TROUBLE SHOOTING GUIDE

SYMPTOM	CHECK	ACTION
SYSTEM WILL NOT ACTIVATE	Check PCU for proper System operation by "PUSH TO TEST" Button on right side of PCU	If LED Activation Indicator flashes, Check bollards for proper alignment and sensors shields for obstruction. Check push buttons connections. If LED Indicator does not flash, check PCU components.
IN-ROADWAY WARNING SIGNALS FLASHING DIMLY, OR NOT AT ALL	Check all in-roadway warning signals for damage	Remove & Replace (R & R) with spare warning signal as needed.
	Check all in-roadway warning signal window ramps for blockage or debris.	Broom any debris from pavement around in-roadway warning signals to allow for unobstructed motorist viewability.
	Check all in-roadway warning signal light modules for proper flash operation	View in-roadway warning signals from 150' to 200' away for the approaching motorists' perspective. R & R with spare warning signal as needed.
	Insure that enclosure components are operational	Shut off power to PCU via circuit breakers and disconnect battery. Check battery voltage. Load test battery 3-4 AMP. Tighten wire connections, and/or remove, and look for corrosion and retighten. Perform a wire push/pull test to verify wires are firmly installed. Power up PCU with battery only. Check voltage at battery to assure that battery has minimum of 12.5 Volts. Document counters and log date, time of service, and name of personnel repairs. List any repair findings. <u>Secure system door</u>
GRAFFITI OR PAINT ON BOLLARDS OR ENCLOSURE EQUIPMENT	Check for proper activation operation	Remove graffiti or paint. Tagster Graffiti Emulsifier from Rhomar Industries is recommended. Call (800) 688-6221 to order.
SYSTEM ON CONSTANT BLINK * PCU FLASHING 50/50	Check for stuck PB or mis-Aligned Bollards	Inspect PCU display for diagnostic information. System enters "Default Flash Pattern" to alert maintenance crews that attention is required

- Routine maintenance should include periodic on-site inspections of the System for proper operation.
- Check activation system for proper operation and tighten fastening hardware as needed.
- Clean bollards and sensor shield if needed and check for proper bollard alignment and activation.
- In-roadway warning signals should be visually checked for sufficient light output with window ramps swiped clean as needed. Should window ramp become obscured over time, remove and replace with spare warning signal.
- Check for proper adhesion of all warning signals to the roadway surface. Fill any gaps around in-roadway signal assemblies with bituminous hot stick to prevent debris or moisture intrusion.
- Inspect wire trench cuts for sufficient loop sealant and fill where needed with filler or bituminous hot stick material.
- Check enclosure and sign mounts for secure attachment and tighten fastening hardware as needed.
- Note/Record activation counts using PCU keypad functions 1, 2, or 3, then reset to clear by pressing 0, then 555 (NOT MANDITORY)
- Note and clean any graffiti from enclosure equipment. (We recommend Tagster™ Graffiti Emulsifier from Rhomar Industries - Springfield, Missouri - (800) 688-6221 - Email: rhomarind@aol.com)

8.2 INITIAL INSTALLATION

After initial installation, the following steps should be followed to test/validate correct operation and to ensure proper operation in the future. Installation should consist of all components secured appropriately and all electrical connections terminated as required.

Step 1 Energize all circuit breakers

Step 2 Contact LightGuard Systems to obtain a 3 digit ACTIVATION CODE for warranty & maintenance tracking purposes. (888) 247-2974

Step 3 Verify that no LED fault/activation indicators are ON in the PCU. These indicators are 2 rows of LED (Yellow & Green) directly below the PCU housing in the enclosure. If any fault/activation indicators are on, check Bollard alignment, push buttons, and field wiring connections.

Step 4 Press keypad 9 to initiate constant blink. Verify that all IRWL & optional illuminated LED signs & Push Buttons are active

Step 5 Press keypad 9 to toggle constant blink off

Step 6 Test and verify that all activation mechanisms are operating (PB & Bollards) and trigger a blink activation. If any of the Bollards activate the system when exiting the crosswalk instead of entering the crosswalk, swap A & B wires in control panel for that Bollard pair.

Step 7 Set cross time as required (refer to section [2.8.3](#))

8.3 FIELD RELATED TOTAL PREVENTATIVE MAINTENANCE

8.3.1 SCOPE

This procedure describes the recommended process for inspecting & maintaining LGS equipment after installation. This section applies to Illuminated signs, electrical interface cabinets, In Roadway Warning Lights (IRWL), and activation mechanisms (Bollards & Push Buttons).

8.3.2 MAINTENANCE PERIOD

Perform Preventative Maintenance/Inspection approximately every 6 months.

8.3.3 MATERIAL REQUIRED

- A. Battery tester
- B. Non-Metallic Whisk broom
- C. Soapy water and cloth

8.3.4 RECOMMENDED SPARES

- A. IRWL

8.3.5 ELECTRICAL INTERFACE CABINET (AC, SOLAR, ECP)

1. Open Electrical Interface cabinet
2. Clean any foreign matter that might have accumulated inside cabinet, (spider webs etc.)
3. Test battery voltage, if value is less than 12VDC refer to trouble shooting guide (section [8.1](#))
4. Optional activation data, (consider posting on inside cabinet door for recordation review).
 - a. use keypad 1 & 3 to display activation history, record activation data (date & number of activations) on paper and store in LGS enclosure
 - b. reset activation counters using keypad 0, then 555 to clear activation history
5. Press keypad 9 to verify that all light outputs activate, press 9 again to toggle outputs back to ready mode
6. SOLAR powered systems
 - a. If solar panel has foreign matter on it, clean solar panel using water
 - b. Verify that the charge controller indicates that the batteries are being charged & warranty period (date) on batteries is valid

8.3.6 ILLUMINATED SIGNS

1. Verify that light windows in illuminated signs are clear of debris, and properly aligned to target path, and all LED modules operate fully.

8.3.7 ACTIVATION MECHANISMS

1. Push buttons
 - a. verify that LED lenses on push button placards are clear of debris
 - b. verify that push buttons activate flash sequence (Four LED indicators each sign)
2. Bollards
 - c. Verify that Bollards are aligned (indicated by Electrical Interface Panel LED's LD1 through LD12 are all NOT illuminated)
 - d. Verify that Bollard courtesy lights are illuminated (refer to section [4.3](#))
 - e. Ensure that Bollard sensors are clean with no obstructions inhibiting sensor performance
 - f. Ensure that Bollards are SOLIDLY secure to mounting pads by attempting to "rock them"

8.3.8 IRWL

1. Verify that all IRWL illuminate when system is activated
 - a. if any IRWL do not activate, refer to troubleshooting guide in LGS Installation Manual
2. Verify "self clearing" design is keeping debris build-up clear from front of units, (If needed wipe window with wet cloth).
3. Within 60-90 days of Initial installation, verify that each IRWL is secure/seated in base plate. If loose, then remove IRWL, clean mating surfaces, and reinstall in accordance with LGS Installation Manual. Repeat at 6 month intervals.
4. If any IRWL are broken, then replace units
5. Inspect IRWL for signs of condensation. If from approximately 200 feet this presents a noticeable decrease in performance or signal head visibility, it should be replaced. If condition does not appear to affect the light visible to the motorist, it may not need replacement (review warranty in T's & C's).

8.4 EQUIPMENT LIST

This section describes standard components of the LightGuard family of products applicable to this Installation Manual.

8.4.1 SPARES & REPLACEMENTS EQUIPMENT LIST

The following list contains LGS model names/numbers for items typically sold as spares or replacements.

ITEM	DESCRIPTION
LGS-SN-LED	Amber LED module for illuminated signs
LGS-BOL SENS ASSY	T3 bollard sensor assembly – RCVR, XMTR, swivel mount, bracket
LGS-GEL-PLUGS	IRWL electrical splice connection inside base plate
LGS-ORING	IRWL sealing oring
LGS-PB ONLY	Push button mechanism
LGS-GRAYHILL RELAY	Magnecraft relay for obsolete back panel
LGS-CDMRLY	Crydom relay for obsolete back panel
LGS-9X-1	Signal head only - red LED
LGS-9X-2	Signal head only - bi-color red/amber LED
LGS-9X-3	Signal head only - amber LED
LGS-9X-4	Signal head only - white LED
LGS-CHS 14	Base plate only - 14" snowplow resistant
LGS-PCU-MICRO	Lgs-micro controller module for PCU
LGS-SD10-C-FG	Base plate only - 10" composite
LGS-SOL-PANEL-ONLY	Solar panel for LGS 2' x 4' (80 watts)

8.4.2 STANDARD EQUIPMENT LIST

The following list contains LGS model names/numbers for Standard items applicable to this Manual.

ITEM	DESCRIPTION
LGS-SOLAR SYSTEM	Solar Powered PCU w/Programmable Interface, Batteries, Cabinet & Panel
LGS-SOLAR SYS-DUAL ZONE	Solar System with Dual Independent Zone Upgrade
LGS-ECP-1	Entry Level LGS Control Panel and Cabinet
LGS-ECP-2	Entry Level LGS Control Panel - custom applications only
LGS-PCU/A DUAL	Dual Zone A/C PCU w/ Battery Backup & Programmable Interface, Cabinet
LGS-PCU/BKPN-AC	AC Power Control Unit w/Backpan, Battery Backup & Programmable Interface Only
LGS-PCU-AC	Standard A/C PCU w/Programmable Interface, Battery. Backup, Backpan & Cabinet
LGS-9X-3/CHS-14	Amber LED Signal Head w/ Snow Plow Resistant 14"Base Plate
LGS-9X-3/SD10-C	Amber LED Signal Head w/ 10" Composite Base Plate
LGS-9X-1/CHS-14	Red LED Signal Head w/ Snow Plow Resistant 14"Base Plate
LGS-9X-1/SD10-C	Red LED Signal Head w/ 10" Composite Base Plate
LGS-9X-2/CHS-14	Bi-Color LED Signal Head w/ Snow Plow Resistant 14"Base Plate
LGS-9X-2/SD10-C	Bi-Color LED Signal Head w/ 10" Composite Base Plate
LGS-PBA-BRAILLE	ADA 2" Push Button Assembly w/ Braille Placard- Pair
LGS-PBA-PAIR	ADA 2" Push Button Assembly w/LED Placard - Pair (L & R)
LGS-PBA-POL-PAIR	ADA 2" Push Button Assembly w/LED Placard & Audible Message-Pair
LGS-ISAD/UNIBOLLARD-SET	In Surface Unit & Automatic Pedestrian Detection Bollard Activation (set)
LGS-RAD	Remote Activation Detector
LGS-T3	Automatic Pedestrian Detection Bollard
LGS-W11-8	Fire Station Sign & LED Enhanced Symbol
LGS-W11-GC	Golf Cart Crossing Sign & LED Enhanced Symbol
LGS-W16-7P	Arrow Sign
LGS-W47	Highway Rail grade Crossing Sign & LED Enhanced Symbol
LGS-W54/W-11A-2	Ped Sign w/ Crosswalk Lines & LED Enhanced Symbol
LGS-W54-AW11-2	Ped Sign w/out Crosswalk Lines & LED Enhanced Symbol
LGS-W54-AW11-2-B	Ped Sign w/ Crosswalk Lines & LED Enhanced Border
LGS-W54-AW11A-2-B	Ped Sign w/o Crosswalk & LED Enhanced Border
LGS-W63/S-1-1	School Sign w/ Crosswalk Lines & LED Enhanced Symbol
LGS-W63/S-1-1-B	School Sign w/ Crosswalk & LED Enhanced Border
LGS-W66/S-2-1	School Sign w/out Crosswalk Lines & LED Enhanced Symbol
LGS-W66/S-2-1-B	School Sign w/o Crosswalk & LED Enhanced Border
LGS-W79/W-11-1	Bicycle Crossing Sign & LED Enhanced Symbol
LGS-ISAD	In Surface Activation Device Only
LGS-T3I	Unibollard/ISAD Activation Unit (part as a pair w/ISAD)
LGS-B/P 16-10-4	4" Aluminum Pole w/ Aluminum Breakaway Base
LGS-BONDO	Two Part Epoxy for Securing Base Plate Into Roadway (pass thru item)
LGS-CAB-SOL	Pad Mount Enclosure for Solar or AC Systems
LGS-PCU-ASSEMBLY	A/C Power Control Unit Only - No Enclosure or Backpan
LGS-AC BEACON-KIT	Separate 110VAC Wig-Wag Output Simultaneous w/ Signal Head Flashing
LGS-AC-OUT-UPGRD	Separate 110VAC Output Simultaneous w/ Signal Head Flashing
LGS-DC BEACON-KIT	Separate 12VDC Wig-Wag Output Simultaneous w/ Signal Head Flashing
LGS-DC-OUT-UPGD	Separate 12VDC Output Simultaneous w/ Signal Head Flashing
LGS-NOVAX-UPGD	Upgrade LGS Controller for Novax Audible Alert

9 ADDENDUMS

This section is reserved for addendums typically applicable to various upgrade kits noted as optional equipment in [Section 1.6](#). Each addendum is supplied separately with appropriate upgrade kit.